

Polaris General XP HD Front Forward Arms



sales@highlifter.com



800-699-0947 | 8:00am - 5:00pm CST



7455 Atkinson Drive, Shreveport, LA 71129



www.highlifter.com

Parts Available For These Popular Brands and Others



PRODUCT DISCLAIMER

The installation of products sold or manufactured by High Lifter Products, Inc. including, but not limited to suspension components such as lift kits, gear reduction lifts, frame stiffener kits, snorkels, and tires that exceed the original specifications for the vehicle, may change the vehicle's center of gravity and handling characteristics both on- and off-road. You are aware that the installation of tires that are larger than original vehicle specifications may reduce the effectiveness of the braking system. Use of these products may place added stress to the original factory vehicle components which could cause them to weaken or possibly fail.

Products sold or manufactured by High Lifter Products, Inc. are intended for off-road use only. Operation of a vehicle modified with these products on a road could result in serious bodily injury or death, and such operation may violate the laws of your state or municipality. You agree to operate your vehicle exclusively in the manner intended by the vehicle manufacturer. You agree that failure to safely and reasonably operate your vehicle could result in serious bodily injury or death, and that, as a result of installation of this product(s) to your vehicle, extreme care must be taken to prevent vehicle rollover or loss of control, which may be more likely to occur as a result of said modifications. You will avoid unsafe maneuvers, including sudden sharp turns or other abrupt maneuvers, which could make a vehicular accident more likely. You understand that High Lifter Products, Inc. is not responsible or liable for any damages or any injuries to yourself or your passengers that could occur upon possible accidents due to driver error, incorrect installations, bad judgment, incompatibility with other aftermarket accessories or natural disasters to the fullest extent allowable by law.

You will have all vehicle occupants fasten seatbelts, if equipped, and wear proper safety equipment, such as DOT approved helmet and eye protection prior to operating the vehicle. You understand and acknowledge that failure to wear proper safety equipment may increase the risk of serious bodily injury or death to yourself and any passengers.

Proper installation of products sold or manufactured by High Lifter Products, Inc. requires knowledge of the factory recommended procedures for removal and installation of original equipment components. Installation of these products without proper knowledge and experience may affect the performance of these components and the safety of the vehicle and cause serious bodily injury or death. It is strongly recommended that a certified mechanic familiar with the installation of similar components perform the product(s) installation.

Prior to installing any products sold or manufactured by High Lifter Products, Inc., you will perform or cause to be performed an inspection of their vehicle to confirm its condition is suitable for the installation of these products. A proper inspection of the vehicle includes confirmation that the vehicle has not been in a collision and is free of corrosion. If the vehicle is suspected to have been in a collision or misused, or is otherwise unsuitable for modification, you will not install the product(s). You will continue to inspect the vehicle prior to each use to confirm its condition is suitable for its intended use, and you acknowledge that the failure to do so may result in serious bodily injury or death, as well as damage to the vehicle itself.

You will install any warning labels provided with the product so it may be prominently seen by yourself and all passengers. You will notify all passengers of the modifications performed to your vehicle prior to operation.

Insurance companies may handle coverage of a modified vehicle differently. Please check with your insurance carrier prior to modifying the vehicle to ensure your coverage remains sufficient.

Installation of this product(s) may void your vehicle warranty. If this is a concern, please check with the manufacturer or dealer before purchase or installation of this product(s).

HIGHLIFTER

PARTS DIAGRAM

FRONT LOWER & UPPER ARMS

(HDDFA-GEN1XP)

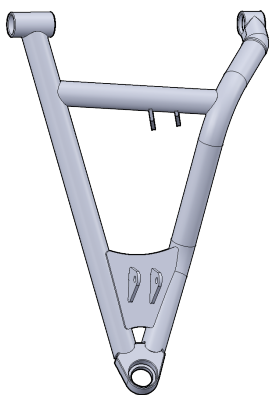

79-14982-L
Front Upper
Left Control
Arm (1ea)



79-14990-L
Front Lower Left
Control Arm (1ea)



79-14990-R
Front Lower Right
Control Arm (1ea)

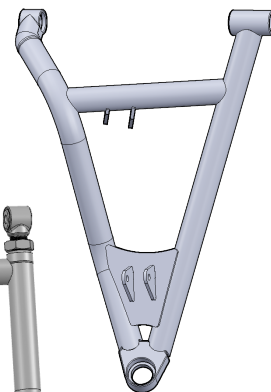

79-14982-R
Front Upper
Right Control
Arm (1ea)



133B
79-14813
Brake Line
Clamp (1pak)



47S
73-11678
Steering
Stop (2ea)



104A
79-10051
Retaining Ring
(4ea)



LOCTITE-02
54-60936
Red Loctite
(1ea)



T50RB
54-61341
8" Zip Tie
(2ea)

GENERAL XP TIE ROD ASSEMBLY



73-16101
Tie Rod
Weldment



79-15126
Misalignment
Stud (2ea)



146Y
79-14420
Misalignment
Bushing (2ea)



MFW12
54-61027
12mm Flat
Washer (2ea)



LJN58F
54-60930
5/8" Jam Nut
(2ea)



20T
79-10719
Heim Joint
(2ea)



JN34F
54-60881
3/4 - 16 Jam
Nut (2ea)



HL-TRE-002
78-10225
Inner Tie-Rod
(2ea)



MLN
54-96044
M12 x 1.5mm
Lock Nut (2ea)



BJP-4
79-12098
Ball Joint
(4ea)



APX-BJP-4
79-12062
Apex Ball Joint
(4ea)

BALL JOINTS (optional)

1



FRONT PASSENGER SIDE

KEEP ALL FACTORY HARDWARE.

Place **jack** under the **FRONT center** of the UTV and lift until the weight is off the suspension. Ensure that the vehicle is properly secured, so that it is stable on the jack. **ONCE LIFTED, USE JACK STANDS TO PROPERLY SECURE THE UNIT.**

Remove the front wheels.

2

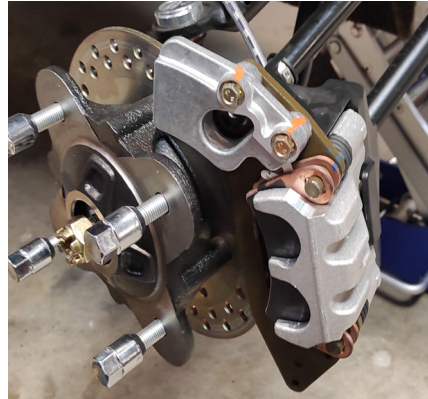
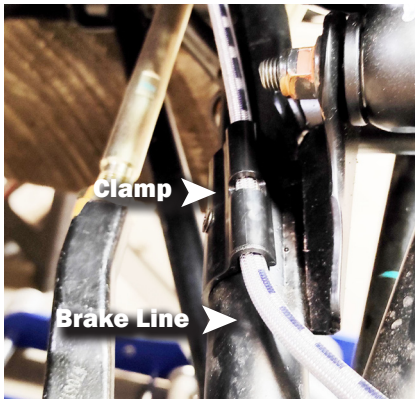

Slide the brake lines out from under the **clamps** that hold the lines to the arm.

Next, remove the bolts connecting the **brake calipers** to the knuckle and set them aside.

DO NOT DRAIN BRAKE FLUID!

3

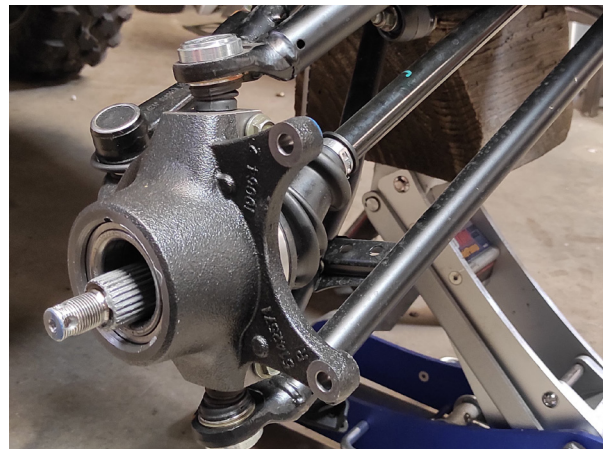
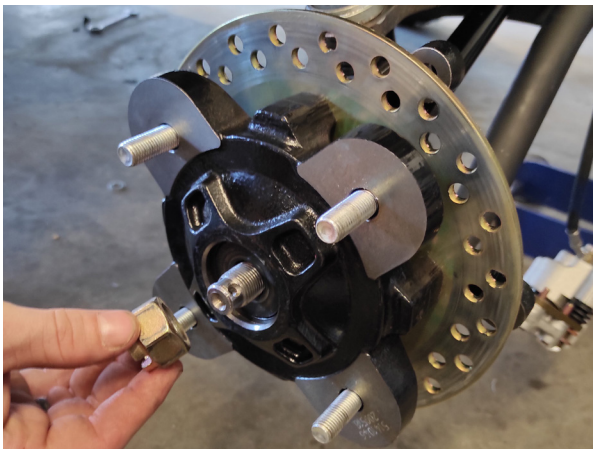

Remove and keep the **cotter pin, axle nut, and washers** from the hub assembly. **YOU WILL REUSE THE FACTORY HARDWARE** to reconnect the new control arms to the frame.

4

REPEAT STEPS FOR OPPOSITE SIDE

4 Before removing the upper and lower arms from the front hub assembly, first disconnect:

- A. Tie rod**
- B. Lower sway bar link end**
- C. Lower shock end**
- D. Upper Ball joint**

NOTE: Some models DO NOT have sway bar links.

TIE ROD



LOWER SWAY BAR MOUNT



LOWER SHOCK END



UPPER BALL JOINT

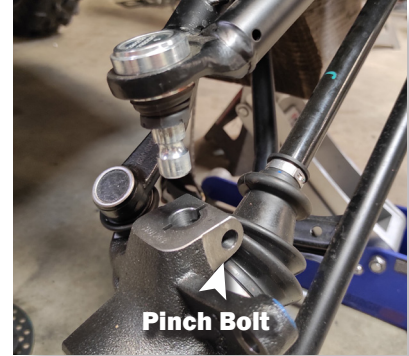

5

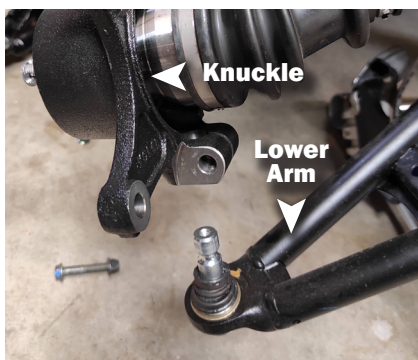

Remove the Lower Arm FIRST by disconnecting the bolt from the knuckle and bolts at the frame.

KEEP ALL FACTORY HARDWARE



Disconnect the **Upper arm** by removing the bolts from the frame.

KEEP ALL FACTORY HARDWARE

REPEAT STEPS FOR OPPOSITE SIDE

6

NOTICE: DO NOT REMOVE THE STEERING ASSEMBLY. THE IMAGES FEATURED ARE FOR DEMONSTRATIVE PURPOSES ONLY.

BOOT REMOVAL

The rubber boots on the steering assembly are held on by zip ties. Cut the zip ties that secure the boots to the inside of the rack.

START WITH THE DRIVER'S SIDE

This side has the least amount of room. If you install the spacer on the passenger side first, you will have less play on the driver's side. **DO NOT REMOVE THE FACTORY SPACER ALREADY IN PLACE.** Turn the steering wheel all the way to the **RIGHT**, place the steering stop (73-11678) between the inner tie rod joint and the rack and pinion. It is a tight fit, so you may have to force it on, this is to ensure that the spacer stays in place.

PASSENGER SIDE

Turn the steering wheel all the way to the **LEFT**. Install the steering stop (73-11678) to the rack.

RESECURING BOOT

Turn the steering wheel closer to the center to allow play in the boot. Slide the boot back down and secure it at both ends with an 8" zip tie.

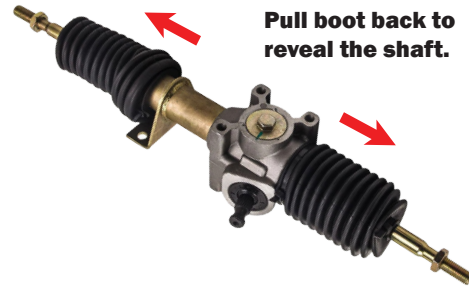

Pull boot back to reveal the shaft.

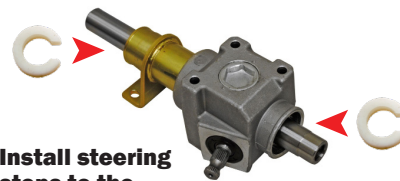

Install steering stops to the shafts on the steering rack.

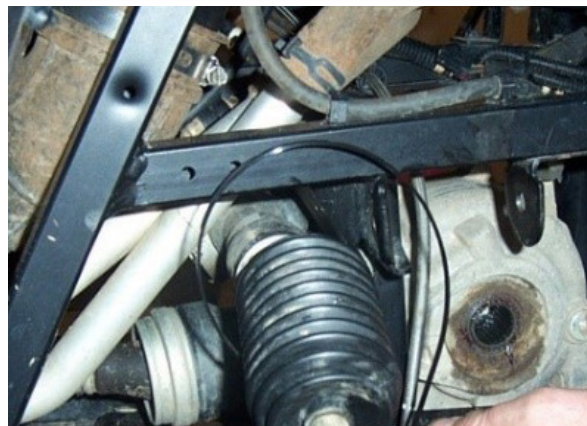
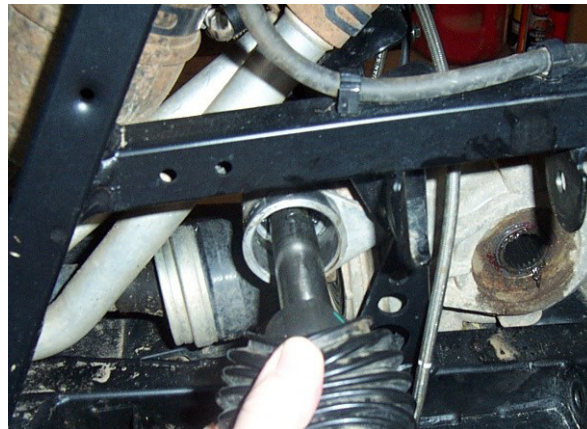
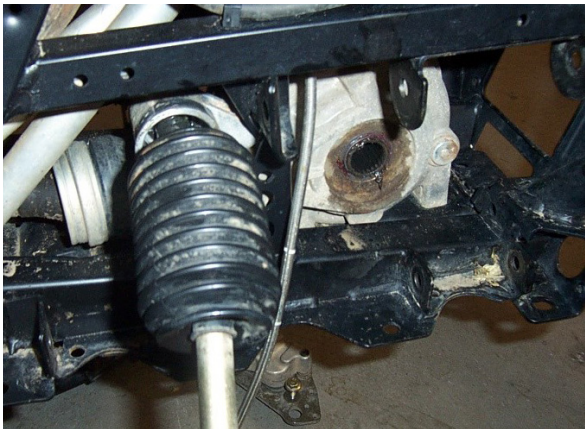

7 IF YOU ORDERED ARMS WITH PRE-INSTALLED BUSHINGS SKIP THIS STEP.

IF YOU HAVE ACCESS TO A BLIND BEARING PULLER WE HIGHLY RECOMMEND USING THIS TOOL OVER A PUNCH. USING A PUNCH MAY CAUSE DAMAGE TO THE BUSHINGS.

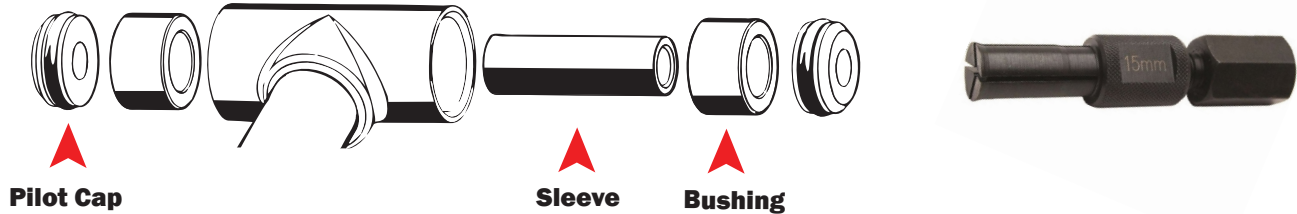

UPPER & LOWER ARM

THE REMOVAL TECHNIQUE IS THE SAME FOR BOTH UPPER AND LOWER ARMS.

- Remove **pivot caps** and **sleeves** from the arm.
- Use a **blind bearing puller** or a **flat punch** to remove the **bushings**.
- Use caution when removing the bushings from the collar. There is a stop built into the factory arm that prevents the bushing from pushing out when installed. Because of this, **the bushing must be pushed out from the opposite side.**

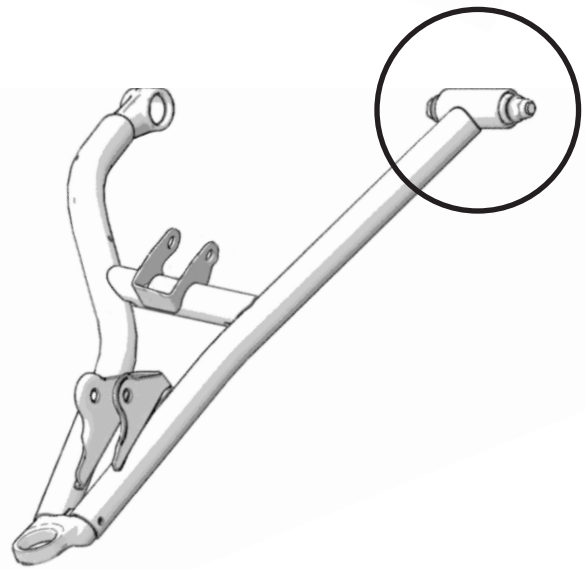

If you use a punch, use caution. You will need to reuse your factory pivot caps, bushings, and sleeves. Make sure that you inspect your bushings for wear or damage. Replace as needed.

REPEAT STEPS FOR OPPOSITE SIDE

8 UPPER ARM

IF YOU ORDERED ARMS WITH PRE-INSTALLED BUSHINGS SKIP THIS STEP.

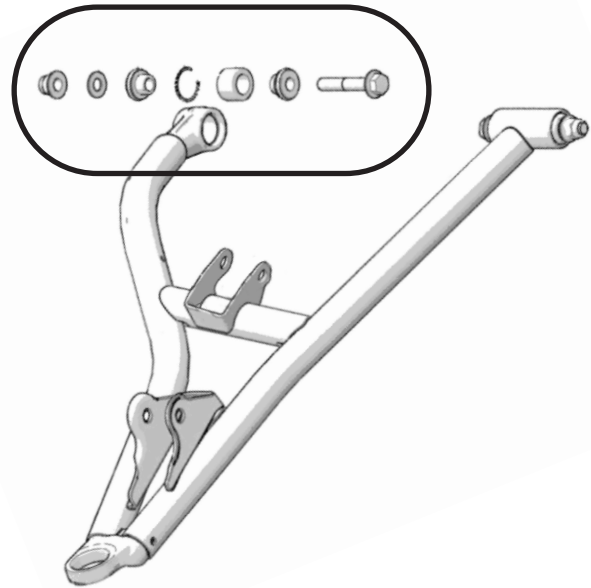
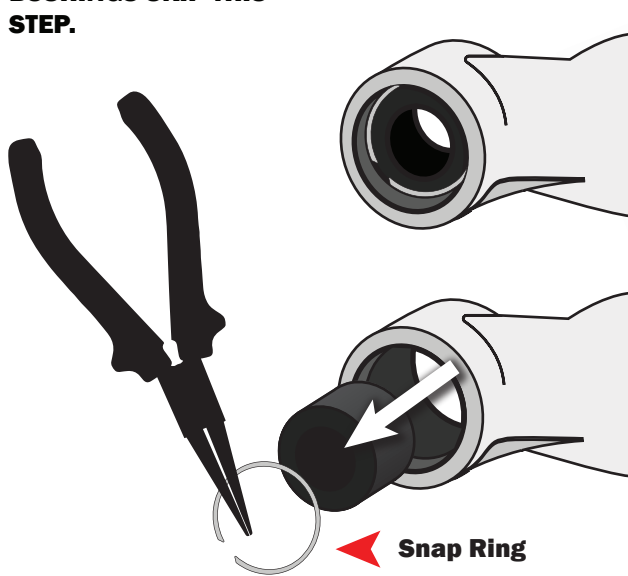

THE BUSHING WILL ONLY COME OUT FROM THE SIDE WITH THE SNAP RING. Remove the bushings and snap ring from the factory arms.

NOTE: Use caution when removing the bushing from the collar. There is a stop built into the factory arm that prevents the bushing from pushing out when installed.

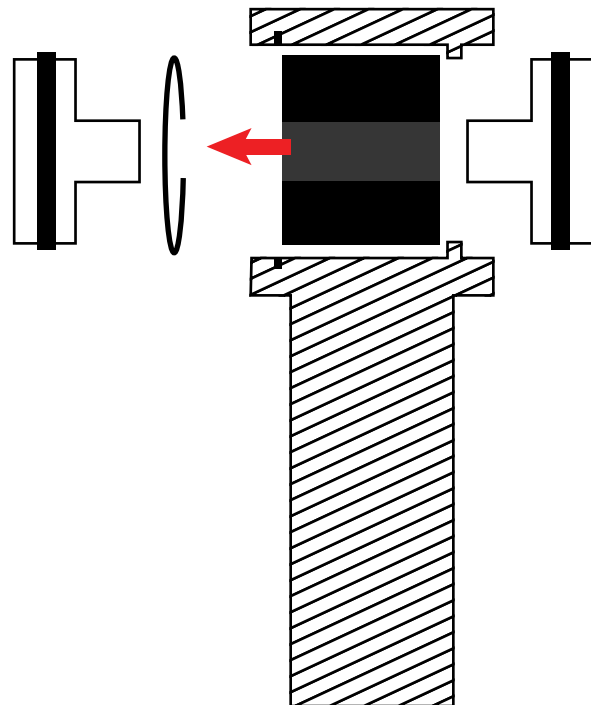

9 UPPER ARM

**IF YOU ORDERED ARMS WITH PRE-INSTALLED BUSHINGS
SKIP THIS STEP.**

On the new upper arms there is **NOT** a stop built into the collar on one side. Instead there will be new snap rings that will prevent the bushings from moving.

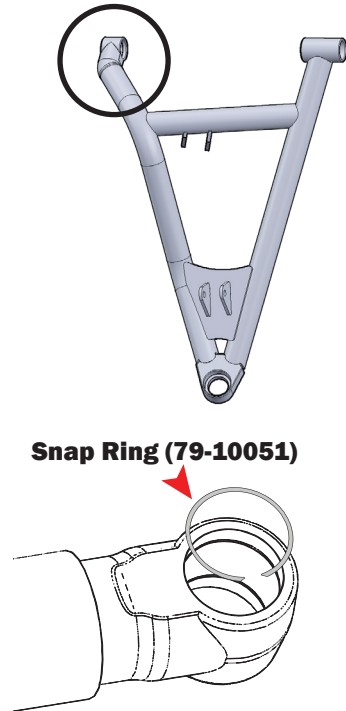

Snap Ring (79-10051)

Insert a snap ring (79-10051) into one side, then insert the bushing into the other side.

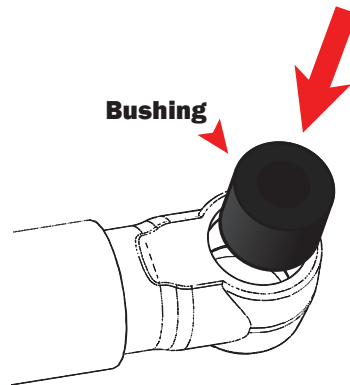

Once the bushing is in place, use a socket of the same diameter as the outer race to press it in all the way.

Apply grease to outer race to ease install.

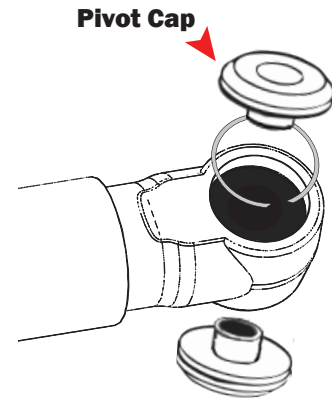

Once the bushing is seated place the other snap ring into place and place the pivot caps on the ends. **NOTE:** You may need to free the snap ring groove of debris with a pick. Debris will prevent the snap ring from seating.

REPEAT STEPS FOR OPPOSITE SIDE

10

WARRANTY WARNING:

The warranty for this product will not cover improper installation of ball joints. Any claim relating to a ball joint issue will require inspection before eligibility for warranty can be determined. If the ball joint area shows damage due to improper installation such as, ridges, scarring, impact marks or other signs of improper installation, the warranty will be not be approved.

TIPS AND CHECKS

Review the following steps if you are installing ball joints into your new High Lifter Control Arm Kit



Verify the ball joint hole is free of paint or materials that could prevent a successful press fit. If there is overspray or paint build up on the top or bottom of the ball joint hole that was missed during manufacturing, use a razor blade, utility knife, or sharp edge to clean the openings on both sides of the ball joint hole. **DO NOT USE A GRINDER OR POWER TOOL!** This will remove more than paint and can ruin the control arm.

11 IF YOU HAVE PRE-INSTALLED BALL JOINTS SKIP THIS STEP

NOTE: FOR DEMONSTRATIVE PURPOSES WE USED THE LOWER CONTROL ARM, BUT THE PROCESS IS SIMILAR FOR BOTH. A press or a vise is recommended for removing and replacing the ball joints.



12 Flip the control arm over, and using the same process, press the ball joint in using a vice or press. If you press in the ball joint crooked, DO NOT TRY TO FORCE IT IN! If you try to force it straight you can “egg” the opening. Press the ball joint out and reinsert it into the opening, pressing it in with a vise. Verify that the clip snaps into place after installing the ball joints into the new Control Arm. You should always double check the ball joint snap ring for proper fit. Even if you use snap ring pliers, it may not seat. You can use a flathead screwdriver and a hammer to tap the snap ring to ensure that it is seated into the groove.

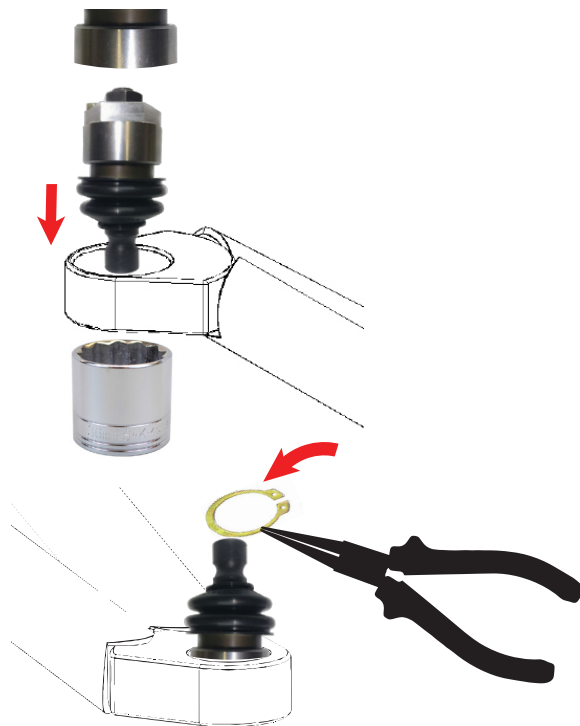

BALL JOINT ORIENTATION

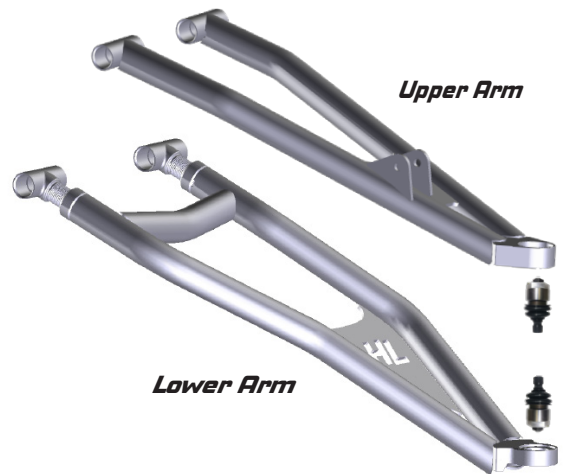

Snap the retaining clip down on to the base of the ball joint.

REPEAT STEPS FOR OPPOSITE SIDE

FRONT UPPER CONTROL ARM

Install

13

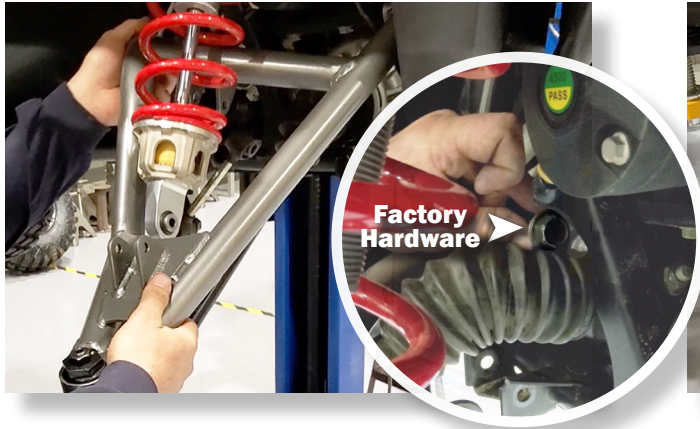

Using factory hardware, connect the new UPPER arm to the frame.

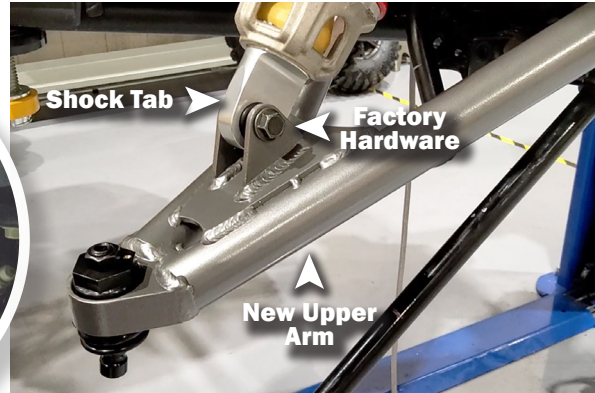

Connect the shock tab to the upper arm using stock bolt. Connect the sway bar, if your machine has one.

FRONT LOWER CONTROL ARM

Install

14



Connect the new LOWER arm at the frame using the factory hardware.

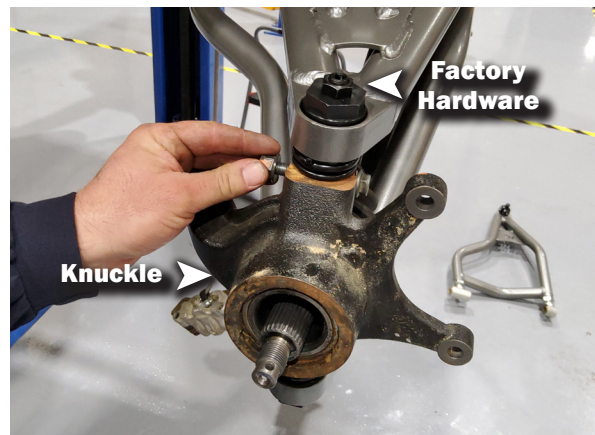

Reinstall the knuckle. Connect the UPPER arm FIRST. Then connect the LOWER arm.

FRONT HUB ASSEMBLY

Install

15



Connect the hub at the LOWER pinch bolt FIRST, then slide the axle through AFTER.

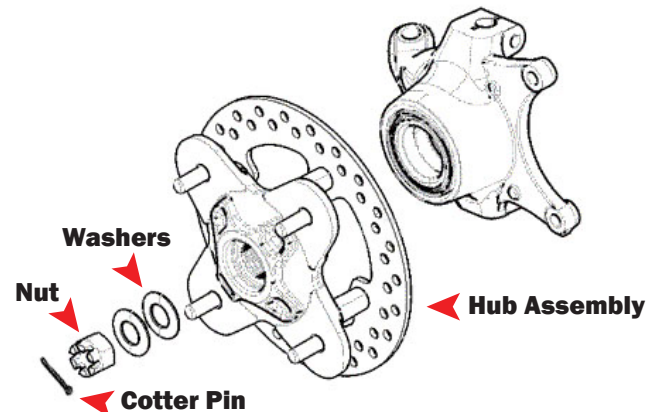

Reattach the rotor to the knuckle assembly. Install the washers, axle nut, and cotter pin.

12

REPEAT STEPS FOR OPPOSITE SIDE

16



Use Red Loctite on threads of heavy duty inner tie rod.



Install inner tie rod. Remove nut.



Install stock boot. Zip tie to boot to rack.

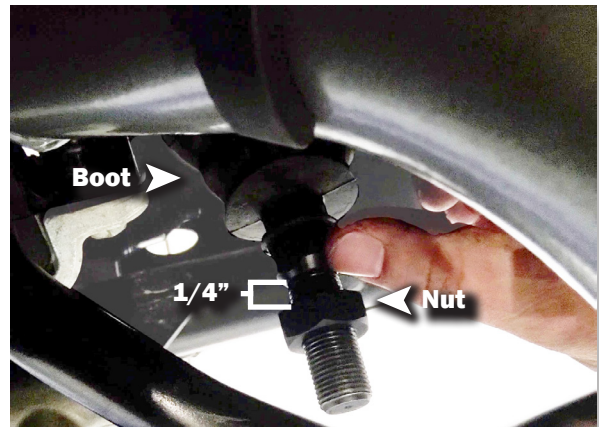

Install nut. Leave 1/4" threading between nut and boot.

17

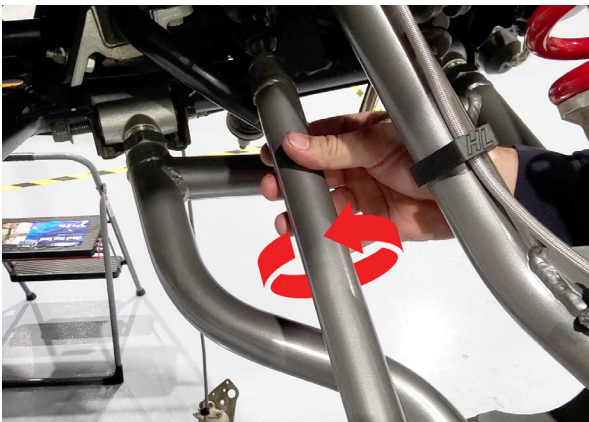

Install tie rod bar to inner tie rod. Rotate left to tighten.

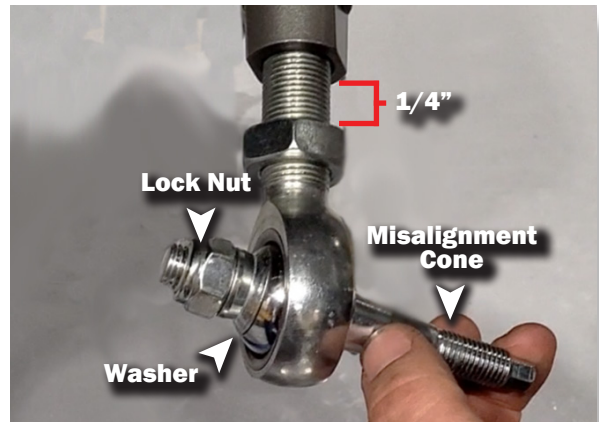

Install misalignment cones, 12mm washer, and 12mm lock nut to end of tie rod. Leave 1/4" threads between tie bar and tie bar end.

REPEAT STEPS FOR OPPOSITE SIDE

18

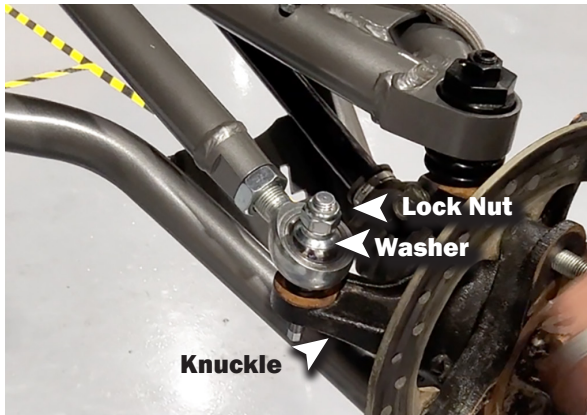

Attach tie rod to knuckle.

Secure with 12mm lock nut, 12mm washer, and misalignment cone.

19

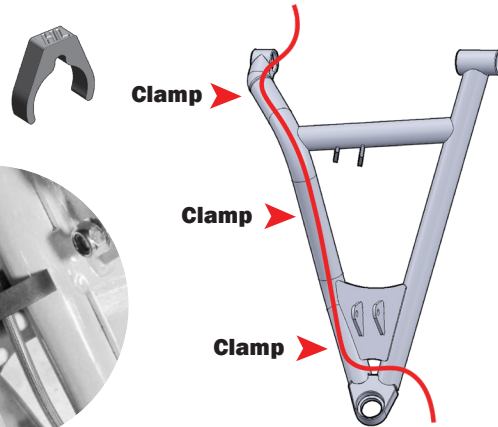
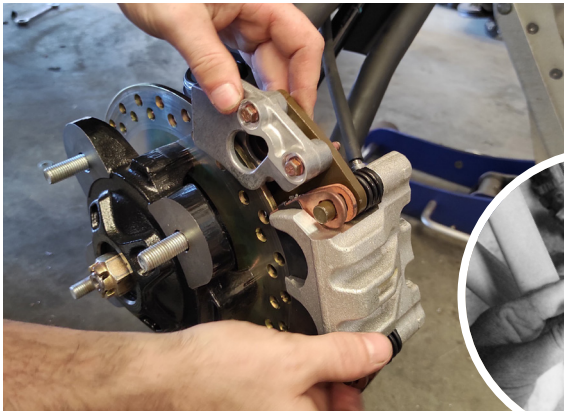

Connect the caliper to the hub assembly by securing the factory bolts. Make sure that you route the brake lines so that they DO NOT come in contact with moving parts and don't become pinched. Connect the (3) brake line clamps (79-14813) along the rear of UPPER the arm -similar to the stock routing.

20 BEFORE STARTING

- Tires must be off the ground
- Tires must have equal air pressure
- Suspension components must be completely assembled

The new High Lifter lower control arms will come pre-adjusted to factory length, which is .937"

If you need to re-adjust the collars, place the factory arm and new control arm on a flat surface. Measure from eyelet to center mount on the factory arm, and then adjust the new arms to those lengths.

NOTE: When re-adjusting, leave the jam nuts loose. Do not fasten tight until installed on UTV, after all final adjustments have been made.

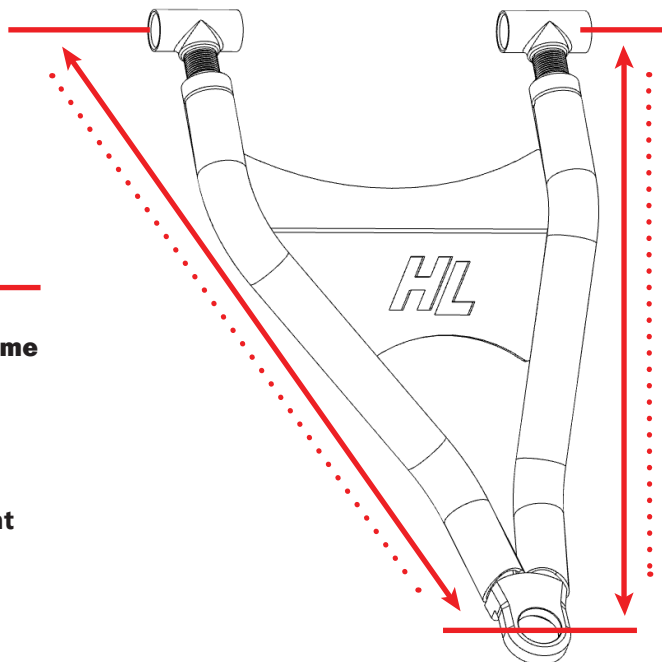

Make all adjustments in small increments.

Do this by disconnecting control arms at the frame and adjusting collars. Once small adjustments have been made. Take the UTV off the jack and roll it back and forth several times before checking the camber. Repeat steps as needed. After alignment is complete, tighten jam nuts to 80 ft-lbs and secure it with blue loctite.

Positive Camber

If you have a positive camber you will need to adjust the collar **OUTWARD** or lengthen the control arm. The maximum amount outward is "1.250" which could give up to 3° of negative camber.

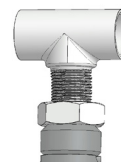

Correct Camber

For this application, we recommend a camber setting of 0°. Collars are preset to .937"

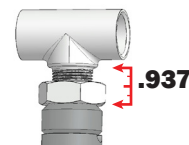

Negative Camber

If you have a negative camber you will need to adjust the collar **INWARD** or shorten the control arm. The maximum amount inward is zero threads exposed and could give over 3° of positive camber.

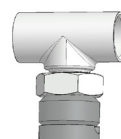

FRONT WHEEL ALIGNMENT

21

IF YOU HAVE ADJUSTABLE CONTROL ARMS, YOU MUST ADJUST THE CAMBER FIRST BEFORE PROCEEDING. DO NOT INSTALL WHEELS ONTO UTV UNTIL PROPER ALIGNMENT HAS BEEN ACHIEVED.

- Straighten steering wheel
- Make sure that the brake rotors are straight to sight or level.
- Using a tape measure, measure from inside to inside on the front and back ends of the rotors.

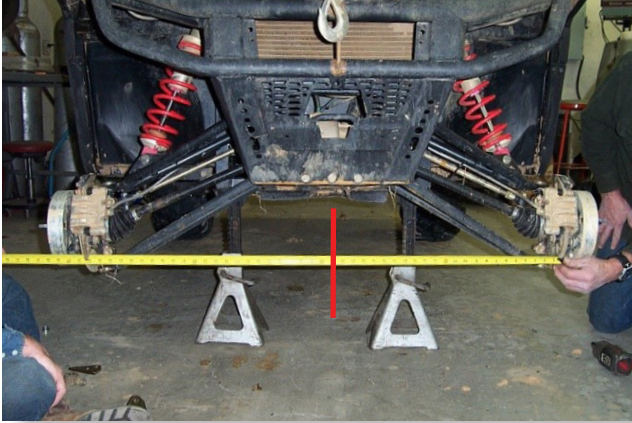

INCORRECT TOE

If the toe alignment is incorrect, measure the distance between vehicle center and the back of the rotors. This will indicate which tie rod needs adjustment.

ADJUSTING TOE

- Adjust tie rods until **BOTH** measurements are the **SAME**, then adjust toe tolerance.

The recommended vehicle toe tolerance is **1/8" to 1/4" (3.175-6.35mm) toe out**. This means the **FRONT MEASUREMENT IS WIDER THAN THE REAR MEASUREMENT**.

TOE ADJUSTMENT CHART

TOE (Inches)	1/16	1/8	3/16	1/4	5/16	3/8
TOE (Degrees)	0.12°	0.25°	0.38°	0.51°	0.64°	0.76°

Recommended Settings



If the **FRONT OF THE WHEELS** are facing **OUT**, adjust the tie rods **OUT** or **INCREASE the length of the tie rod**.

Measurement at the front of the tires will be **GREATER** than the rear, if the **TOE IS OUT**.



If the **FRONT OF THE WHEELS** are facing **IN**, adjust the tie rods **IN** or **REDUCE the length of the tie rod**.

Measurement at the front of the tires will be **LESS** than the rear, if the **TOE IS IN**.



IMPORTANT NOTE: When tightening the tie rod jam nuts, the tie rod ends must be held parallel to prevent rod end damage and premature wear. Damage may not be immediately apparent if done incorrectly.

After alignment is complete, tighten & torque tie rod end jam nuts to specifications. **[12-14 ft lbs]**

22

IF YOUR STEERING IS ALREADY CENTERED SKIP THIS STEP.

Factory steering for some makes and models may **NOT** be centered. This can cause the tie rod ends to have more engagement on one end than the other. This also causes the steering wheel to be off center.



A) When the steering is zeroed, check the steering wheel to make sure that it is properly positioned.



(B) If the steering wheel is not centered, you will need to remove the center cap with a flat head screwdriver to gain access to the steering wheel nut.



(C) Using a ratchet, turn the steering nut counter clockwise or left. Continue this until the steering wheel locks at full turn, then loosen the nut. **DO NOT** remove the nut yet.



Once the nut is broken loose, back it off just enough leaving a few threads. Use a hammer to tap on the nut while pulling up on the steering wheel until it breaks loose. But **DO NOT** hammer too hard, it could damage the nut or threads. Now remove the nut and steering wheel.

NOTE: A puller may be needed to remove the steering wheel if it can't be broken free.

Now will be the time to adjust the steering wheel accordingly. Re-place the wheel and make sure the wheels are turned back straight. The steering wheel should be straight up and down.

NOTE: Rolling vehicle back and forth may help straighten the wheels.

Once the wheel is straight, thread the nut back on and turn the nut clockwise until the steering wheel locks at full turn, then tighten the nut. Reinstall the steering wheel cap.

NOTE: Loctite may be needed for the steering nut.

HIGHLIFTER



HIGH LIFTER LIMITED LIFETIME WARRANTY

High Lifter offers a Limited Lifetime Warranty to the original purchaser that our product shall be free from defects in material and workmanship for the life of the product if utilized in accordance with the manufacturer's instructions for installation and operation of said products.

LIMITED LIFETIME WARRANTY EXTENDS TO THE FOLLOWING PRODUCT LINES:

- **Lift Kits (Signature, Standard and Big Lifts)**
- **Control Arms**
- **Trailing Arms**
- **Radiator Relocation Kits**
- **Portal Gear Lifts**
- **Wheel Spacers**
- **Tow Hooks**
- **Control Arm Link Kits**

Damages to vehicle or any other object during the installation, use, or removal of High Lifter products are not covered under this warranty. Normal wear items included with any of the products covered under this Limited Lifetime Warranty are excluded from coverage. These items include, but are not limited to heim joints, tie rods, bearings, bushings, seals, gaskets, zinc plating, painted and powder coated finishes. Other exclusions of coverage under this warranty include, but are not limited to: damage or product failure due to improper installation, lack of maintenance, product modification, abuse, collision or use on vehicles for which product was not designed, repairs performed by anyone other than approved High Lifter personnel or made using non-High Lifter components. This warranty is valid for the original purchaser only and is non-transferable. High Lifter reserves the right to inspect any product before determining if the claim is valid and covered under this warranty. Claims determined to be caused by reasons other than a manufacturer defect will be rejected and an estimate for repair or cost of a replacement product if a repair is not possible, will be provided.

This warranty is exclusive and is in lieu of any implied warranty of merchantability, fitness for a particular purpose or other warranty of quality, whether express or implied, except the warranty of title.

WARRANTY PROCESSING

If you suspect your product is defective, **DO NOT** disassemble the product to determine the cause without prior approval as it may void your warranty status. This is especially true with our Portal Gear Lift. To begin the claim process, please e-mail our warranty team at warrantycare@highlifter.com and include the following in the e-mail:

- Your full name, address and contact phone number.
- The year, make and model of your vehicle
- The part number of the product
- Photos of the product installed, and vehicle product is installed on
- Proof of Purchase (Required for all warranty claims and you must be the original purchaser)

Once a claim is created, you will receive a return authorization number (RMA). Write this number on the outside of the box containing your defective product and include it along with your name and contact information inside the box. Product must be returned in the original box or a box of equal strength and packaging. Product sent without an RMA number visible on the outside of the box or sent COD will be refused. Ship your product to the following address:

High Lifter Products, Inc.

Attn: Returns 7455 Atkinson Drive, Shreveport, LA 71129

Once your product is received, we often have your replacement or repaired product shipped back to you within 3-business days of receiving it. Please note that High Lifter is not responsible for shipping charges on product returned for warranty or repair, including duties and fees required by those residing outside the United States.

THANK YOU FOR CHOOSING
HIGHLIFTER