

# Polaris RZR 1000

**HDRB-RZR1-1-SBI**  
**Apexx 8" Upper Radius Bars**

**HDRB-RZR1-SBI**  
**Apexx 8" Lower Radius Bars**



Parts Available For These Popular Brands and Others

**POLARIS**

*Can-am*



**Kawasaki**



**HIGHLIFTER**



sales@highlifter.com



800-699-0947 | 8:00am - 6:00pm CST



780 Professional Drive North, Shreveport, LA 71105



www.highlifter.com

## PRODUCT DISCLAIMER

The installation of products sold or manufactured by High Lifter Products, Inc. including, but not limited to suspension components such as lift kits, gear reduction lifts, frame stiffener kits, snorkels, and tires that exceed the original specifications for the vehicle, may change the vehicle's center of gravity and handling characteristics both on- and off-road. You are aware that the installation of tires that are larger than original vehicle specifications may reduce the effectiveness of the braking system. Use of these products may place added stress to the original factory vehicle components which could cause them to weaken or possibly fail.

Products sold or manufactured by High Lifter Products, Inc. are intended for off-road use only. Operation of a vehicle modified with these products on a road could result in serious bodily injury or death, and such operation may violate the laws of your state or municipality. You agree to operate your vehicle exclusively in the manner intended by the vehicle manufacturer. You agree that failure to safely and reasonably operate your vehicle could result in serious bodily injury or death, and that, as a result of installation of this product(s) to your vehicle, extreme care must be taken to prevent vehicle rollover or loss of control, which may be more likely to occur as a result of said modifications. You will avoid unsafe maneuvers, including sudden sharp turns or other abrupt maneuvers, which could make a vehicular accident more likely. You understand that High Lifter Products, Inc. is not responsible or liable for any damages or any injuries to yourself or your passengers that could occur upon possible accidents due to driver error, incorrect installations, bad judgment, incompatibility with other aftermarket accessories or natural disasters to the fullest extent allowable by law.

You will have all vehicle occupants fasten seatbelts, if equipped, and wear proper safety equipment, such as DOT approved helmet and eye protection prior to operating the vehicle. You understand and acknowledge that failure to wear proper safety equipment may increase the risk of serious bodily injury or death to yourself and any passengers.

Proper installation of products sold or manufactured by High Lifter Products, Inc. requires knowledge of the factory recommended procedures for removal and installation of original equipment components. Installation of these products without proper knowledge and experience may affect the performance of these components and the safety of the vehicle and cause serious bodily injury or death. It is strongly recommended that a certified mechanic familiar with the installation of similar components perform the product(s) installation.

Prior to installing any products sold or manufactured by High Lifter Products, Inc., you will perform or cause to be performed an inspection of their vehicle to confirm its condition is suitable for the installation of these products. A proper inspection of the vehicle includes confirmation that the vehicle has not been in a collision and is free of corrosion. If the vehicle is suspected to have been in a collision or misused, or is otherwise unsuitable for modification, you will not install the product(s). You will continue to inspect the vehicle prior to each use to confirm its condition is suitable for its intended use, and you acknowledge that the failure to do so may result in serious bodily injury or death, as well as damage to the vehicle itself.

You will install any warning labels provided with the product so it may be prominently seen by yourself and all passengers. You will notify all passengers of the modifications performed to your vehicle prior to operation.

Insurance companies may handle coverage of a modified vehicle differently. Please check with your insurance carrier prior to modifying the vehicle to ensure your coverage remains sufficient.

Installation of this product(s) may void your vehicle warranty. If this is a concern, please check with the manufacturer or dealer before purchase or installation of this product(s).

# HIGHLIFTER

## PARTS DIAGRAM

### UPPER RADIUS BAR HARDWARE (HDRB-RZR1-SBI)



**65K**  
12mm  
Heim  
Bushing  
(4ea)



**17Q**  
10mm  
Heim  
Bushing  
(4ea)



**JN34F**  
3/4-16 Jam  
Nut (2ea)



**MLN12-1.75**  
12mm Lock  
Nut (2ea)



**MFW12**  
12mm  
Washer  
(2ea)



**MCS12X80-10.9**  
12mm x 80mm  
Hex Bolt (2ea)



**96o**  
Spherical  
Bearing  
(2ea)



**127U**  
Upper Radius  
Bar (2ea)



**103H**  
C-Clip  
(4ea)



**92W**  
Tapered  
Bushing  
(4ea)



**82X**  
Inner  
Cone  
(4ea)



**139Z**  
Upper Radius  
Spacer (1ea)



**127T**  
3/4-16 Heim Joint  
(2ea)

### LOWER RADIUS BAR HARDWARE (HDRB-RZR1-SBI)



**65K**  
12mm  
Heim  
Bushing  
(4ea)



**92W**  
Tapered  
Bushing  
(4ea)



**82X**  
Inner Cone  
(4ea)



**140A**  
Lower Radius  
Spacer (2ea)



**127T**  
3/4-16 Heim Joint  
(2ea)



**17Q**  
10mm  
Heim  
Bushing  
(4ea)



**JN34F**  
3/4-16 Jam  
Nut (2ea)



**MLN12-1.75**  
12mm Lock  
Nut (2ea)



**MFW12**  
12mm Washer  
(2ea)



**MCS12X80-10.9**  
12mm x 80mm  
Hex Bolt (2ea)



**96o**  
Spherical  
Bearing  
(2ea)



**127Q**  
Lower Radius  
Bar (2ea)



**103H**  
C-Clip  
(4ea)

1



**PASSENGER SIDE**

**DISCONNECT THE SWAY BAR LINK FIRST BEFORE JACKING UP THE VEHICLE.**



Place jack under the front center of the RZR and lift until the weight is off the suspension. Ensure that the vehicle is properly secured, so that it is stable on the jack.

2

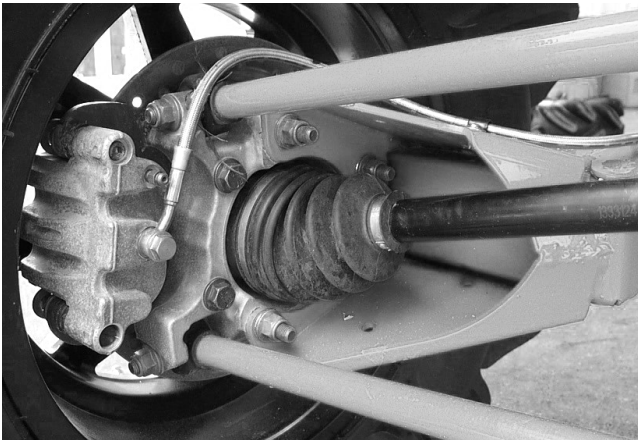

Depending on if you purchased an upper or lower kit, you will only need to disconnect corresponding factory radius bars. This will need to be done at the frame and the hub.



Due to the larger HD inner bung, there may be clearance issues between the hitch and the radius bar end. Because of the nature of a tow hitch, it is often they become bent, over time. If your tow hitch is bent upward, then it will likely need to be bent back down to meet tolerances.

3

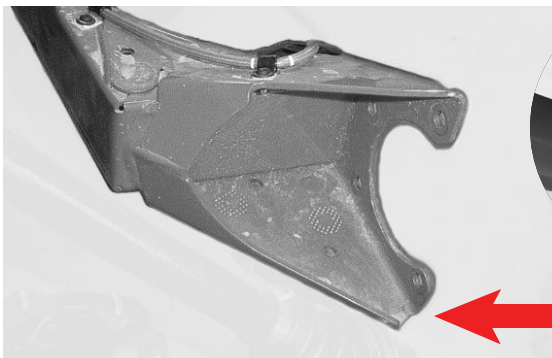

It may be necessary to trim the trailing arm to gain the desired clearance for **JUST THE LOWER RADIUS BARS.**

**TRIM TIP OF TRAILING ARM.**

4

4

**RADIUS BAR**

Pre-assemble the new radius bars. The steps are the same for the upper and the lower.

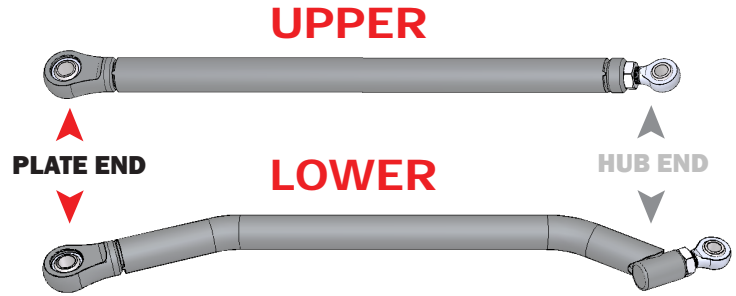

Insert a c-clip (103H) into one side, then place a spherical bearing (96o) into the other side.

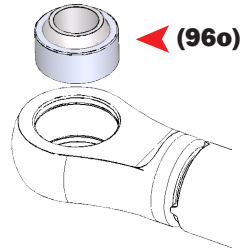

Once the bearing (96o) is in place, use a socket of the same diameter as the outer race to press it in all the way. Apply grease to outer race to ease install.

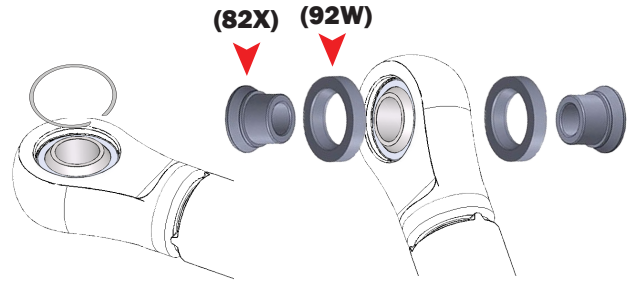

**NOTE:** You may need to clean out the snap ring groove with a fine point or pick. Make sure there is no debris preventing the remaining c-clip (103H) from seating.

Insert the alignment cone (82X) into the bushing (92W), then insert it through the spherical bearing. These will go on both sides of the spherical bearing.

5

**FRAME SPACERS**

FRAME AND FRAME PLATE WILL NEED TO BE DRILLED OUT TO 12MM FOR:



**RZR STANDARD MODEL 2014-2017**  
**RZR HIGH LIFTER EDITION 2015-2016**

Attach the radius bars to the frame using the upper radius spacer (139Z) or Lower radius spacer (140A). Fasten them with the 12x80mm Hex Bolts, 12mm Flat Washers, and 12mm Lock Nuts provided in the kit. Torque to 90ft lbs.

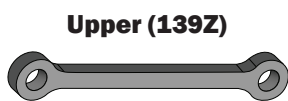

Upper (139Z)



Lower (140A)

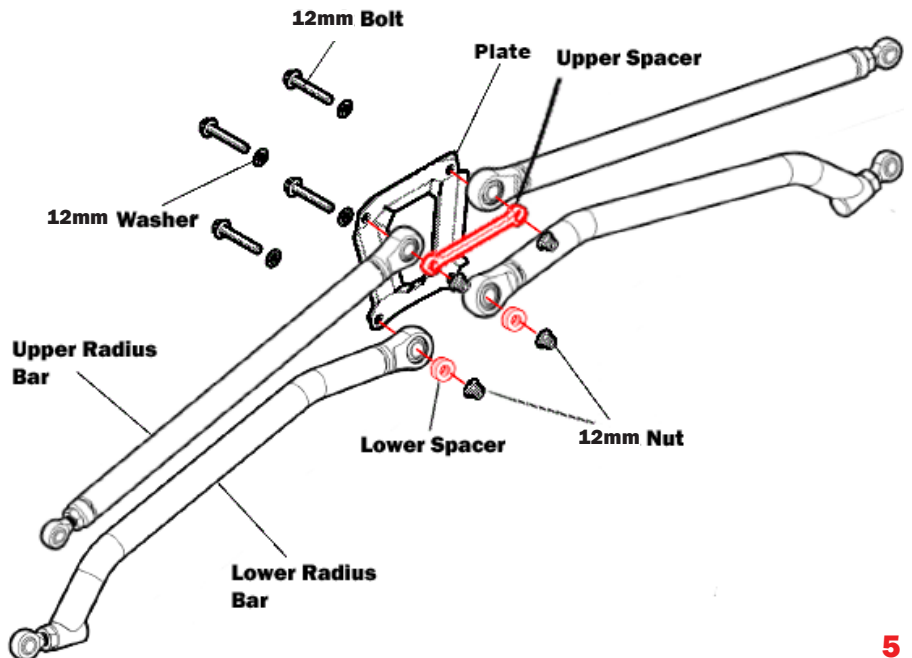

# 6 HEIM ADAPTERS

**12mm: 65K**

Insert the two heim adapters (65K) into the eyelet of the heim joint (127T).

**10mm: 17Q**

Insert the two heim adapters (17Q) into the eyelet of the heim joint (127T).

**1" IN THREAD ENGAGEMENT**

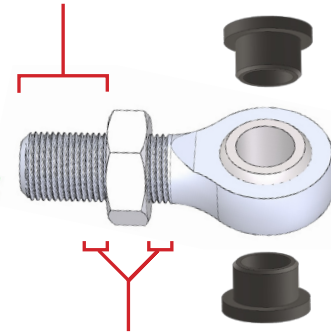

**3/4" IN OF ADJUSTMENT**

## UPPER



▲  
PLATE END

▲  
HUB END

Measure the distance of the stock radius bar from each center hole to the other, then adjust the new HD bar to that length.

Thread the jam nut onto the heim joint (127T). Run it down until the jam nut has 1" of thread from the bottom, then screw the heim joint into the radius bar. This should allow 3/4" in of adjustment.

Attach the upper radius bar to the knuckle assembly using the factory hardware.

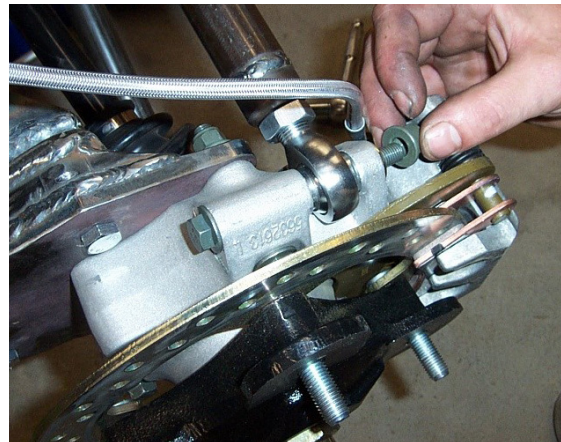

▼  
PLATE END

## LOWER

▼  
HUB END



THE STEPS WILL BE THE SAME AS ABOVE

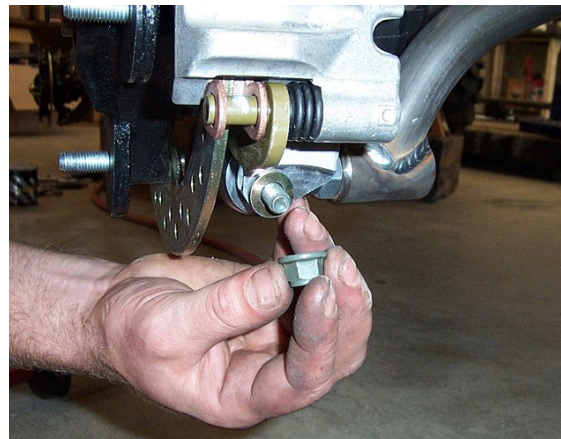

---

**REPEAT STEPS ON OPPOSITE SIDE OF THE VEHICLE**

---

7



Once you have repeated the steps on the opposite side, place the wheels back on the vehicle and lower the jack. Inspect vehicle to make sure all components are secure.

---

**TORQUE ALL BOLTS TO FACTORY SPEC**

---

# HIGHLIFTER



## HIGH LIFTER LIMITED LIFETIME WARRANTY

High Lifter offers a Limited Lifetime Warranty to the original purchaser that our product shall be free from defects in material and workmanship for the life of the product if utilized in accordance with the manufacturer's instructions for installation and operation of said products.

### LIMITED LIFETIME WARRANTY EXTENDS TO THE FOLLOWING PRODUCT LINES:

- **Lift Kits (Signature, Standard and Big Lifts)**
- **Control Arms**
- **Trailing Arms**
- **Radiator Relocation Kits**
- **Portal Gear Lifts**
- **Wheel Spacers**
- **Tow Hooks**
- **Control Arm Link Kits**

Damages to vehicle or any other object during the installation, use, or removal of High Lifter products are not covered under this warranty. Normal wear items included with any of the products covered under this Limited Lifetime Warranty are excluded from coverage. These items include, but are not limited to heim joints, tie rods, bearings, bushings, seals, gaskets, zinc plating, painted and powder coated finishes. Other exclusions of coverage under this warranty include, but are not limited to: damage or product failure due to improper installation, lack of maintenance, product modification, abuse, collision or use on vehicles for which product was not designed, repairs performed by anyone other than approved High Lifter personnel or made using non-High Lifter components. This warranty is valid for the original purchaser only and is non-transferable. High Lifter reserves the right to inspect any product before determining if the claim is valid and covered under this warranty. Claims determined to be caused by reasons other than a manufacturer defect will be rejected and an estimate for repair or cost of a replacement product if a repair is not possible, will be provided.

**This warranty is exclusive and is in lieu of any implied warranty of merchantability, fitness for a particular purpose or other warranty of quality, whether express or implied, except the warranty of title.**

### WARRANTY PROCESSING

If you suspect your product is defective, **DO NOT** disassemble the product to determine the cause without prior approval as it may void your warranty status. This is especially true with our Portal Gear Lift. To begin the claim process, please e-mail our warranty team at [warrantycare@highlifter.com](mailto:warrantycare@highlifter.com) and include the following in the e-mail:

- Your full name, address and contact phone number.
- The year, make and model of your vehicle
- The part number of the product
- Photos of the product installed, and vehicle product is installed on
- Proof of Purchase (Required for all warranty claims and you must be the original purchaser)

Once a claim is created, you will receive a return authorization number (RMA). Write this number on the outside of the box containing your defective product and include it along with your name and contact information inside the box. Product must be returned in the original box or a box of equal strength and packaging. Product sent without an RMA number visible on the outside of the box or sent COD will be refused. Ship your product to the following address:

**High Lifter Products, Inc.**  
**Attn: Returns 780 Professional Dr N Shreveport, LA 71105**

Once your product is received, we often have your replacement or repaired product shipped back to you within 3-business days of receiving it. Please note that High Lifter is not responsible for shipping charges on product returned for warranty or repair, including duties and fees required by those residing outside the United States.

**THANK YOU FOR CHOOSING**  
**HIGHLIFTER**