



# LIFT-116

## 5" Drop Axle Lift Kit

### E-Z-Go TXT Gas 01-08.5

#### Installation Instructions

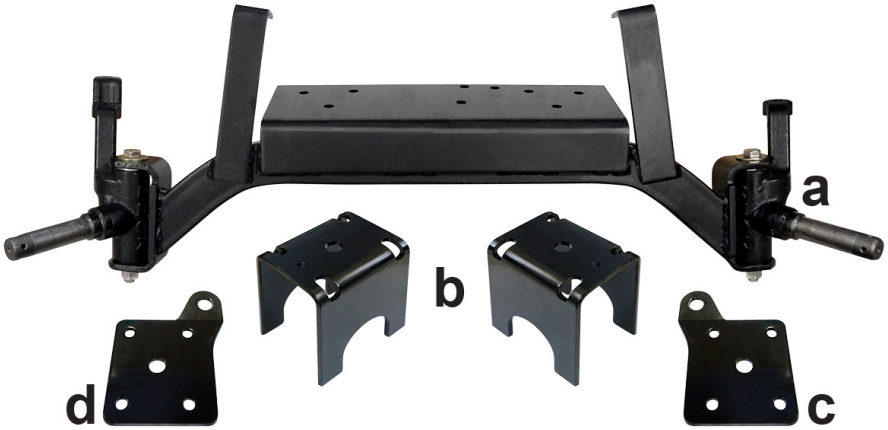

Contents of Kit		QTY
a	5" Drop Axle Assembly	1
b	Rear Lift Blocks	2
c	Shock Mount Plate, Driver Side	1
d	Shock Mount Plate, Passenger Side	1
e	Hardware (Contents on Next Page)	1

**Caution:** Please read through the instructions carefully. Installer is responsible for damage if instructions are not followed properly. Extra installers will be helpful in some parts of the installation. Please refer to torque specifications on page 2 for new hardware. Please refer to the vehicle's maintenance manual for torque specifications on reused hardware.

**Note:** You must install larger tires and wheels once the cart is lifted. Stock wheels will not work. We recommend a 23" tires and a 10" or larger wheel with a minimum of a 1" offset.

## LIFT-116 Hardware Kit



Contents		QTY	Torque Requirements
a	3/8"-16 x U-Bolts	4	38 ft lbs
b	3/8" Flat Washers	8	-
c	3/8"-16 Nylock Nuts	8	-

## Tools Needed for Installation

- Sockets & Wrenches (1/2", 9/16", 14mm, 5/8", 11/16", 3/4", 13/16")
- Adjustable Wrench
- Flat Head Screwdriver
- Pliers
- Floor Jack and Jack Stands
- Chock for Wheels
- Rubber Mallet
- Tie Rod Fork
- Grease Gun
- Safety Glasses

## Installation Preparation (Front)

1. Engage parking brake.
2. Turn key OFF.
3. Chock the back of the rear wheels.
4. Remove the hub caps (if any). Loosen the lug nuts on both front wheels but do not remove them.
5. Place a jack under the front axle. Lift the cart high enough to accommodate the new tires and wheels.
6. Place (2) jack stands securely under the frame and remove the jack.

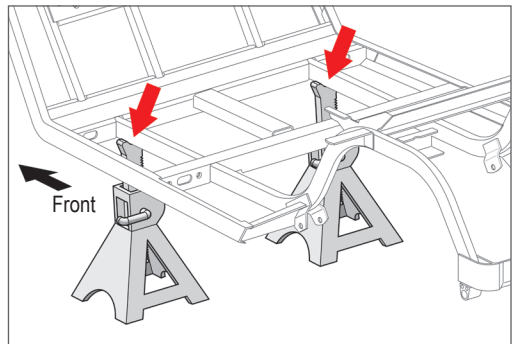
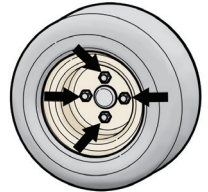

7. Fully remove the (8) front lug nuts, tires and wheels.
8. Remove dust covers, cotter pins, castle nuts (black arrow) and wheel hubs from both spindles. Place hubs in a clean/dry location. Retain all components.
9. Disconnect the tie rod ends from the spindles (red arrow). Use a tie-rod fork to dislodge the tie-rod ends from the spindles. Do not hammer the studs as it will damage the threads. Retain hardware.

**NOTE:** (1) tie-rod end is located on the driver side and (2) on the passenger side.

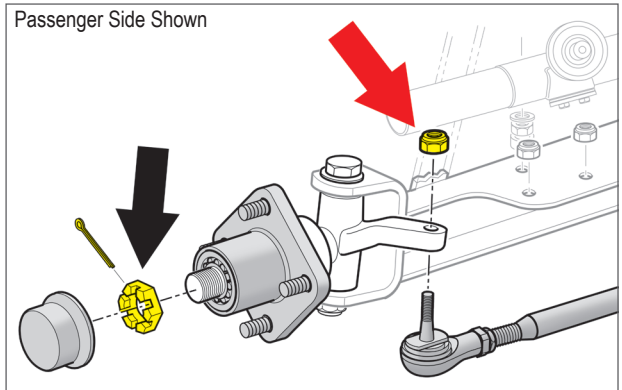

10. Disconnect the steering rack from the front axle (yellow). Retain hardware and spacers. Push the steering rack away from the axle.
11. Disconnect the bottom of the shocks from the shock mounts (blue). Push the shocks up and out of the way. Retain hardware and bushings.
12. Disconnect the front axle from the leaf springs by removing the hardware and spring plates (orange). Retain hardware and plates. Discard axle.

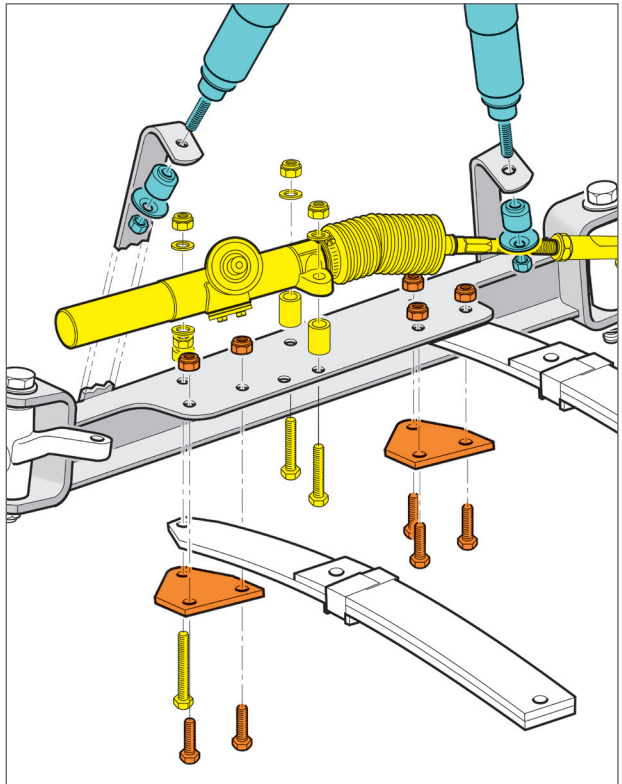

## Front Suspension Installation

**NOTE:** Please refer to page 2 for torque specifications for included hardware. Please refer to vehicle's maintenance manual for torque specifications on reused hardware.

1. Using the Original Hardware and Spring Plates, bolt the new front axle to the leaf springs where the original axle was removed.
2. Attach the shocks to the new shock mounts using the Original Hardware.

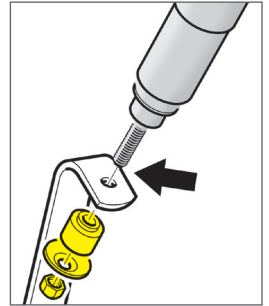

3. Attach the steering rack to the new front axle using the Original Hardware.

**CAUTION:** Do NOT over torque the hardware. Doing so could break the steering box mounting tabs.

4. Attach the (3) tie-rod ends to the new spindles using the Original Hardware.

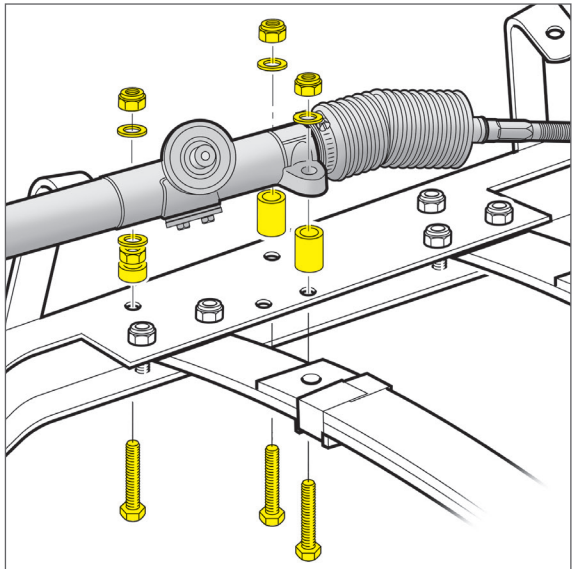
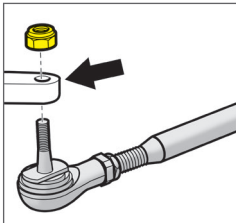

5. Install the hubs on the new spindles using the Original Hardware. Fully tighten the castle nut. If the hole for the cotter pin is not clearly visible, back the castle nut off until the hole is visible. Reinstall the cotter pin and dust cover.

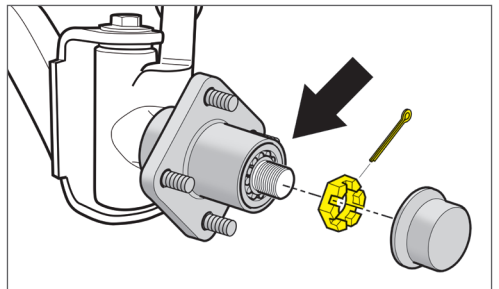

6. Grease the fittings on both spindles using a general purpose automotive grease.

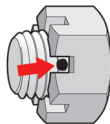

7. Install the (2) front tires and wheels. The stock tires and wheels will not work on the newly lifted cart. Fully tighten the lug nuts on both wheels.

**NOTE:** We recommend 23" tires and a 10" or larger wheel with a minimum of a 1" offset.

8. Tighten any hardware left loose in this section.
9. Once the tires and wheels are fully secure, place the jack under the cart. Remove the jack stands and lower the cart. Remove the chocks behind the rear wheels.

**NOTE:** Toe adjustments will be made at the end of the installation.

## Installation Preparation (Rear)

**Safety Note:** Proper eye and mouth protection should be worn during this section to protect the installer from falling debris when working under the cart.

The rear axle is only secured in place by the leaf springs, U-bolts and the jack. For safety reasons, only complete one side of the suspension at a time.

1. Engage parking brake.
2. Turn key OFF.
3. Chock the front of the front wheels.
4. Remove the hub caps (if any). Loosen the lug nuts on both rear wheels but do not remove them.

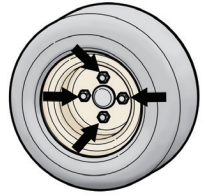

5. Place a jack securely under the rear axle. Safely lift the rear end of the cart enough to accommodate the additional height of the larger tires and wheels.
6. Place jack stands under the chassis on both sides of the cart to stabilize it. DO NOT remove the jack.
7. Fully remove the (8) rear lug nuts, tires and wheels. Discard.
8. Disconnect the bottom of the rear shocks from the shock mounting plates (shown in green, page 6). Push the shocks upward and out of the way. Retain hardware.

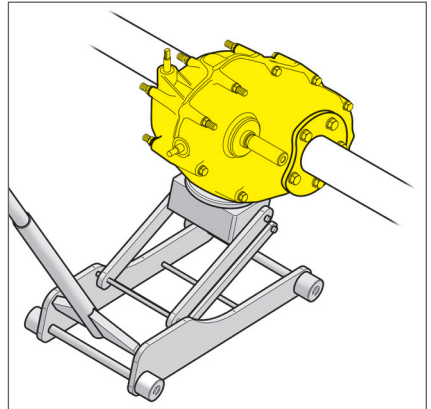

9. With the axle supported by the jack, remove the (2) U-bolts holding the passenger side ISO mount and cap (orange), rear axle, shock mounting plate (blue) and leaf spring (purple) shown on page 6. Discard the U-bolts.

**CAUTION:** Complete one side at a time.

10. Remove the passenger side leaf spring (purple), shock mounting plate (blue), ISO mount and cap (orange) shown on page 6. Retain leaf spring and hardware.

11. Carefully lower the rear axle away from the chassis with the jack. The jack stands will remain in place to support the chassis.

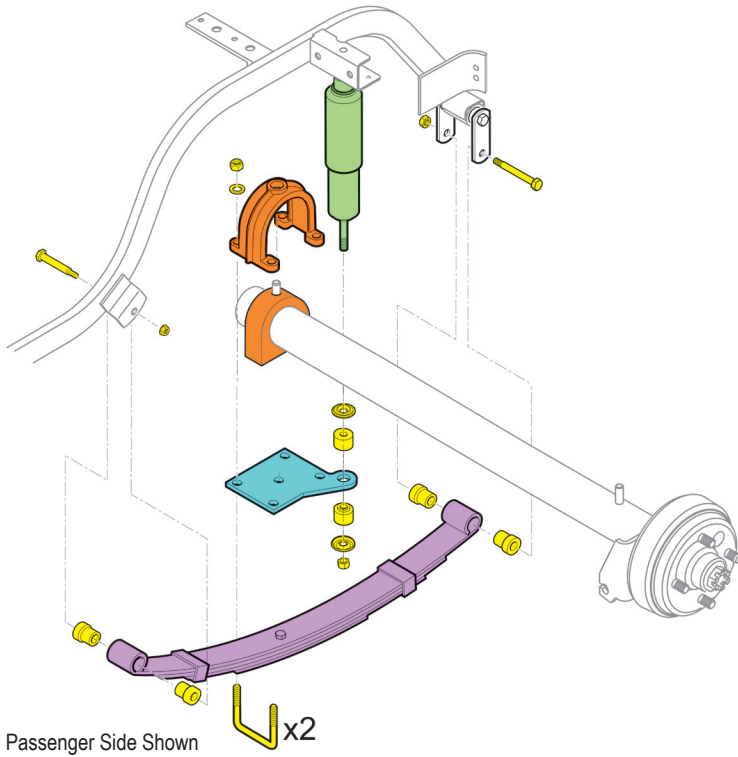

## Rear Suspension Installation

1. Place a lift block (orange, page 7) on top of the axle. The alignment hole on the lift block should sit above the alignment pin on the axle.  
**NOTE:** Some models have brake assemblies that are mounted above of the axle. If these brake assemblies interfere with the lift blocks they can be moved to the bottom side of the axle. Switch the driver side brake assembly with the passenger side brake assembly and mount them under the axle.
2. Place the leaf spring (purple, page 7) on top of the lift block. The alignment pin on the leaf spring will seat in the center hole of the lift block. Reconnect the leaf spring to the front shackle using the Original Hardware.
3. Place the new shock mount plate (blue, page 7) on top of the leaf spring. The center hole on the shock mount plate will align with the alignment pin on the leaf spring.

**NOTE:** The driver and passenger shock mount plates are different. When oriented correctly, the small tab will face upwards towards the shock.

4. Fasten the shock plate, leaf spring and lift block to the axle with (2) 3/8"-16 U-Bolts, (4) Flat Washers and (4) Nylock Nuts. Hand tighten U-bolts evenly on both sides.
5. Repeat prep steps 9-11 and installation steps 1-4 on the driver side.
6. Using the jack, safely lift the rear axle and guide the rear portion of the leaf springs to their original positions. Reinstall the leaf springs (purple) to the rear shackles using the Original Hardware removed in step 10, page 5.
7. Fasten the shocks to the shock mounting plates (blue) using the Original Hardware.
8. Install the (2) new rear tires/wheels on the rear hubs. Remove the jack stands and lower the cart. Remove the jack and chock.

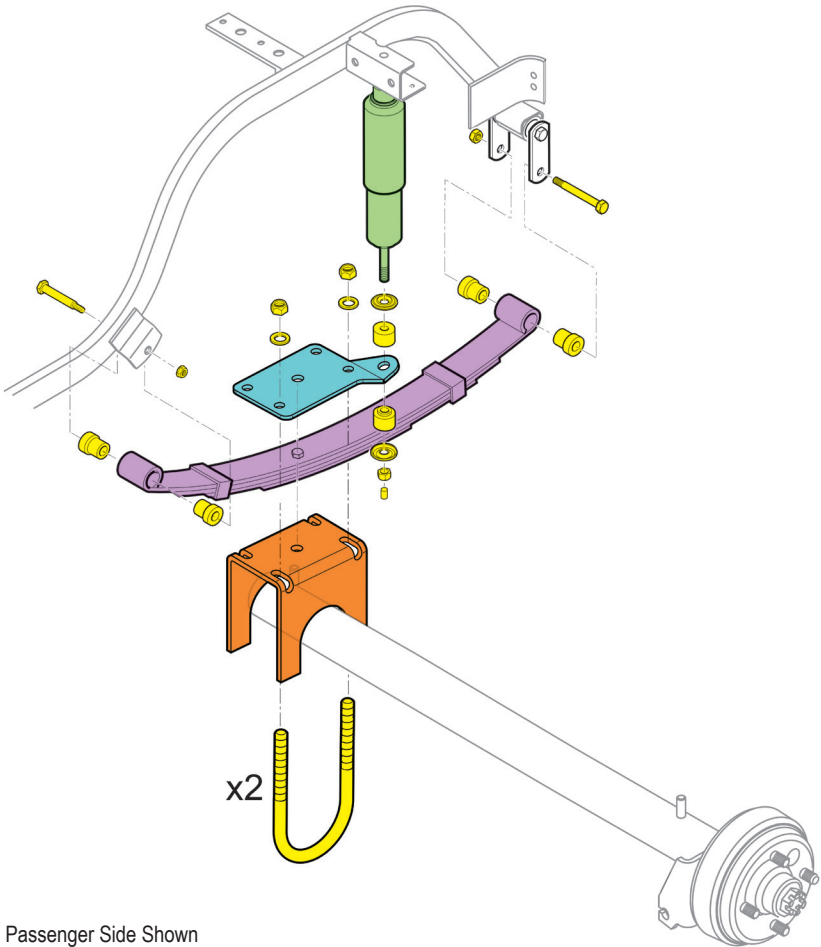

## Adjust the Toe

1. Drive forward and back 20-40 feet to check the toe before making adjustments. Only make adjustments if needed.

**NOTE:** For stability, an 1/8" toe-in is recommended.

2. Calculate the toe of the front tires by measuring the center-to-center distance of the front of the front tires versus the center-to-center distance of the back of the front tires. The front measurement should be 1/8" shorter than the rear.
3. Adjust the toe by loosening the jam nuts. Lengthen or shorten the tie rod by turning the rod adjustment.

**NOTE:** Shortening the tie rods increases the toe, lengthening decreases it.

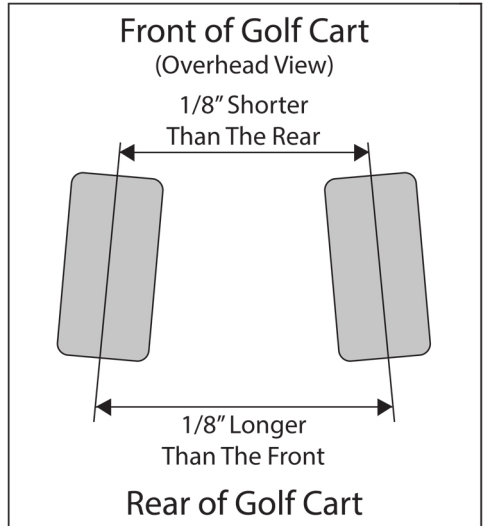

## Toe-In Adjustment

4. Once the toe adjustments are finalized and set, tighten the jam nuts.

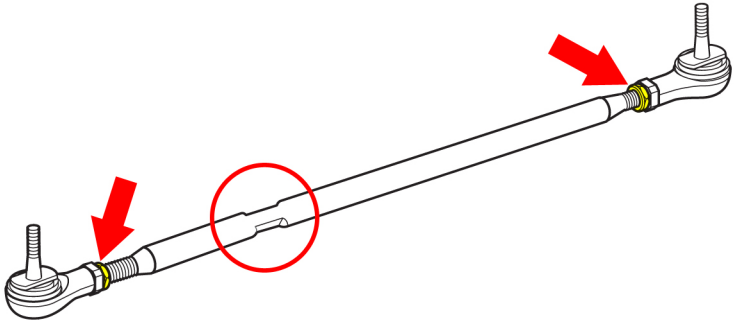

This completes the installation of your RHOX Lift Kit.  
Please enjoy safely! Scan QR code or use the link to view the installation video.  
<https://vimeo.com/user39935056>

