

JAKES LIFT KITS

EZ-GO 2001&1/2 AND NEWER ELECTRIC

AXLE KIT

PART # 6205

PARTS LIST



<u>ITEM</u>	<u>QTY</u>
A. FRONT AXLE	1
B. REAR SHOCK MOUNTS	2
C. STEERING RISER	1
D. REAR LIFT MOUNTS	2
E. 6mm BOLTS WITH LOCKNUTS FOR REAR	8
F. WARNING LABEL	1
G. 2" X 1/2" BOLTS WITH LOCKNUTS	2

JAKES LIFT KITS
EZ-GO 2001&1/2 AND NEWER ELECTRIC
ASSEMBLY INSTRUCTIONS

FRONT INSTALLATION

1. Jack up the front end of the cart and place it on jack stands. You will be installing larger wheels and tires so raise the cart high enough to accommodate for the additional height.
2. Remove the wheels and tires.
3. Remove the tie rod end at the spindle that attaches to the steering box.
4. Remove the spindles from the front axle. Clean and lubricate these bolts and bushings for the reinstallation of the spindles. The two stock mounting holes on the spindle of the passenger side needs drilled out to 1/2" for installation of the steering riser.
5. Remove the front axle from the leaf springs. Clean and lubricate the bolts for installation of the new axle.
6. Using the bolts from the old axle install JAKES front axle (Item C) to the leaf springs.
7. Install the spindles to the new front axle.
8. Install JAKES steering riser (Item C) to the passenger side spindle using the nuts and bolts provided (Item G).
9. Reattach the tie rod joints to the spindles. **NOTE: SOME E-Z-GO MODEL CARTS COME STOCK WITH A TIE ROD LONG ENOUGH! IF THE STOCK TIE ROD JOINTS DO NOT HAVE GREASE FITTINGS FROM WHEEL TO WHEEL YOU WILL NEED TO PURCHASE JAKE'S LONGER TIE ROD PART# 6206. IF YOU ORDERED YOUR KIT WITH THE LONGER TIE ROD INSTALL IT AT THIS TIME.**
10. Securely tighten all bolts.
11. Install JAKES recommended 22 x 11 x 10 wheels and tires with a 3 x 5" offset for maximum performance and stability. **NOTE: Your stock wheels and tires will NOT work!**
12. Take the cart off of the jack stands and lower the cart.
13. Drive the cart forward 10-20 feet and check the toe-in. (Proper toe-in should be approximately 1/8".)

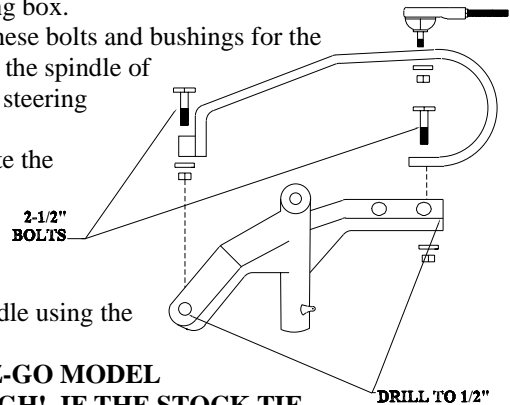

REAR INSTALLATION

1. Jack up the rear end of the cart and place jack stands on the frame in front of the springs. You will be installing larger wheels and tires so raise the cart high enough to accommodate the additional height.
2. Remove the wheels and tires.
3. Unbolt the bottom of the shocks. Clean and lubricate these bolts for later use.
4. Unbolt the rear leaf springs from under the rear end.
5. Place JAKES rear risers (Item D) on top of the axle. **NOTE: Parts are universal. There is no left or right side.**
6. Place the leaf springs on top of the risers.
7. Place JAKES rear shock plates (Item B) on top of the leaf springs with the shock mount holes facing the rear of the cart and towards the center. Using the supplied nuts & bolts (Item E) mount the shock plates to the rear risers with the leaf springs sandwiched in between them. The bolts go through the new shock mount, rear risers, and stock shock mount. Make sure you tighten these bolts evenly.
8. Attach the bottom of the shocks to JAKES new shock mounts on the rear shock plates using the stock nuts and bolts.
9. Use wire ties to fasten the brake cable to either the underside of the springs or the frame.
10. Double check all nuts and bolts for tightness.
11. Install JAKES recommended wheel and tire size 22 x 11 x 10 wheels and tires with a 3 x 5" offset for maximum performance. **NOTE: Your stock wheels and tires will NOT work!**
12. Included is a warning label (Item F) which is to be placed on the steering column or another visible area and is to be read by all operators.