

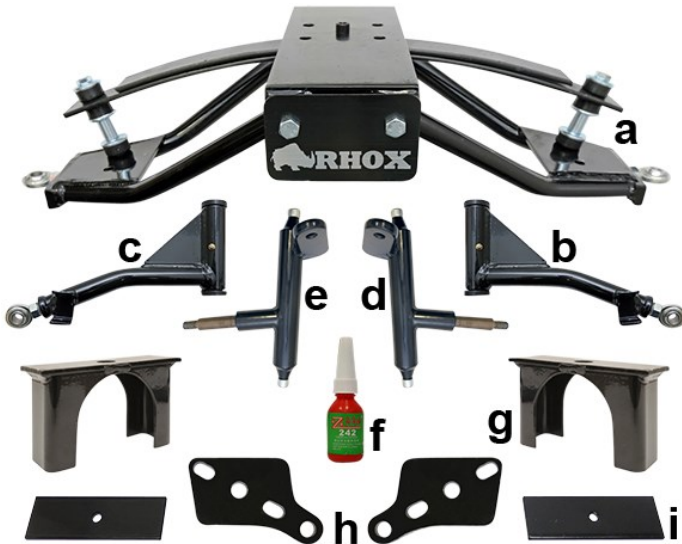

RHOBX

Rugged parts for your ride.

LIFT-543 4" Standard A-Arm Lift Kit Club Car Precedent Installation Instructions



Contents of LIFT-543 Club Car Precedent Lift Kit:

- a (1 ea.) Front Suspension
- b (1 ea.) Driver Side Upper A-Arm
- c (1 ea.) Passenger Side Upper A-Arm
- d (1 ea.) Driver Side Spindle
- e (1 ea.) Passenger Side Spindle
- f (1 ea.) Thread Locking Compound
- g (2 ea.) Rear Lift Blocks
- h (2 ea.) Shock Mounting Plates
- i (2 ea.) Centering Plates
- j (1 ea.) Box of Hardware (Contents on Next Page)

Caution: Please read through the instructions carefully. Installer is responsible for damage if instructions are not followed properly. Extra installers will be helpful in some parts of the installation. Please refer to all torquing specifications on page 2 for installation.

Note: You must install larger tires and wheels once the cart is lifted. Stock wheels will not work. We recommend a 20" tire and a 10" or larger wheel with a minimum of a 1" offset for use on the RHOBX Lift Kit.

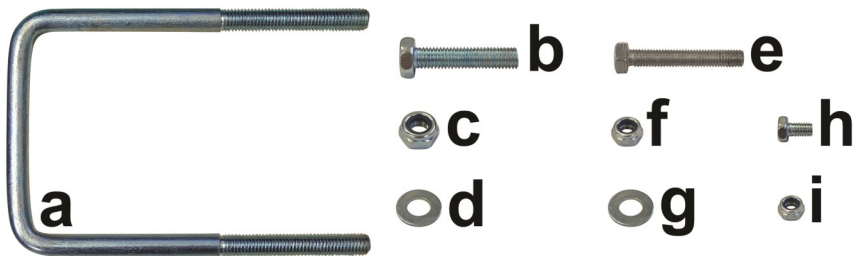

Contents of LIFT-543 Hardware Kit		Qty.	Torque Requirements
a	10mm Square U-Bolts	2	-
b	10mm x 45 Hex Head Bolts	4	45 ft. lbs.
c	10mm Nylock Nuts	4	-
d	10mm Flat Washers	8	-
e	8mm x 50 Hex Head Bolts	2	22 ft. lbs.
f	8mm Nylock Nuts	2	-
g	8mm Flat Washers	4	-
h	6mm x 10 Hex Head Bolts	2	6 ft. lbs.
i	6mm Nylock Nuts	2	-

Tools Needed for Installation

- Sockets & Wrenches (10mm, 13mm, 14mm, 16mm, 17mm, 18mm, 3/4", 13/16")
- Allen Key (3/8")
- Flat Head Screwdriver
- Needle Nose Pliers
- Rubber Mallet
- Grease Gun
- Tape Measure

Installation Preparation (Front of the Cart)

1. Engage parking brake.
2. Turn key OFF.
3. Electric Carts Only: Place Tow/Run Switch in TOW.
4. Chock the back of the rear wheels.
5. Remove the hub caps (if any). Loosen the lug nuts on both of the front wheels but do not remove them.

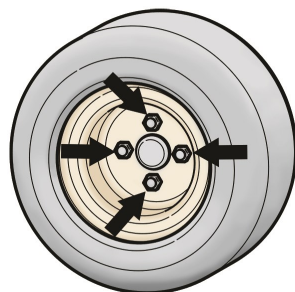

6. Place a jack under the front leaf spring plate (yellow). Lift the cart high enough to accommodate the new tires and wheels. Place (2) jack stands securely under the chassis and remove the jack. Photos are shown without front bumper.

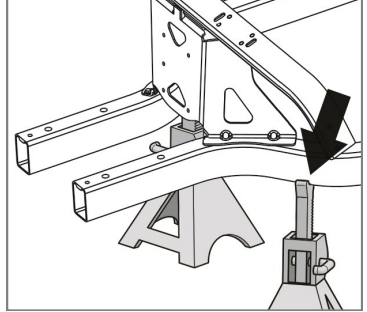
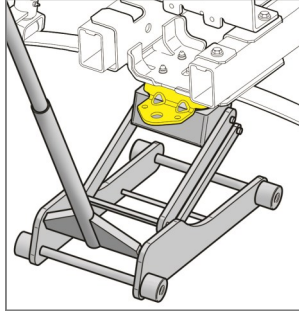

7. Fully remove the (8) front lug nuts, tires and wheels. Discard.
8. Remove the front bumper. Retain bumper and hardware.

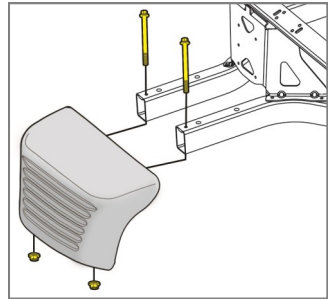

9. Remove dust covers (black arrow), flange nuts (green arrow) and wheel hubs (red arrow) from both spindles. Retain all three components.

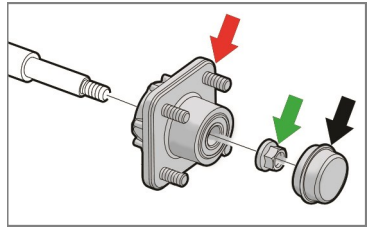

10. Disconnect the tie rod ends from the spindles (black arrow). Retain hardware.
11. Disconnect the shocks from the top clevis (red arrow). Discard hardware.

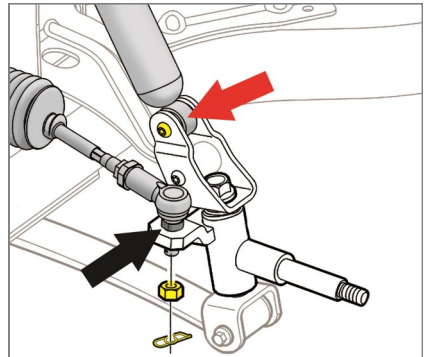

12. Remove the (3) bolts in the steering rack. Retain hardware.

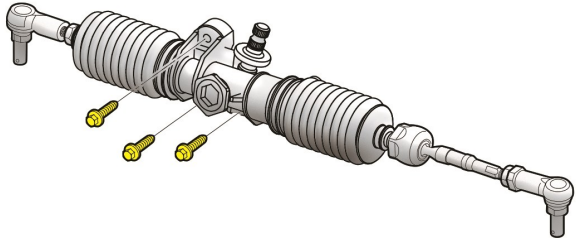

13. Remove the upper A-arms (black arrows). Discard A-arms and retain hardware.

NOTE: Push the steering rack out of the way to access the upper bolts.

14. Remove the original front suspension from the chassis by removing the (4) bolts from under the leaf spring clamp (red arrows). Discard hardware & suspension. Retain leaf spring clamp.

NOTE: Additional help is recommended during this step to support the front suspension.

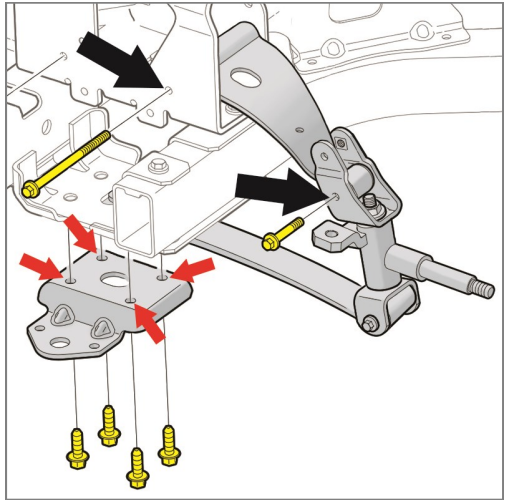

Front Suspension Installation

NOTE: Please refer to page 2 for torquing specifications for included hardware. Please refer to vehicle's maintenance manual for torquing specifications on reused hardware.

1. Install the new A-arms where the original ones were removed using the Original Hardware.
2. Grease the fittings on the upper A-arms using a general purpose automotive grease.

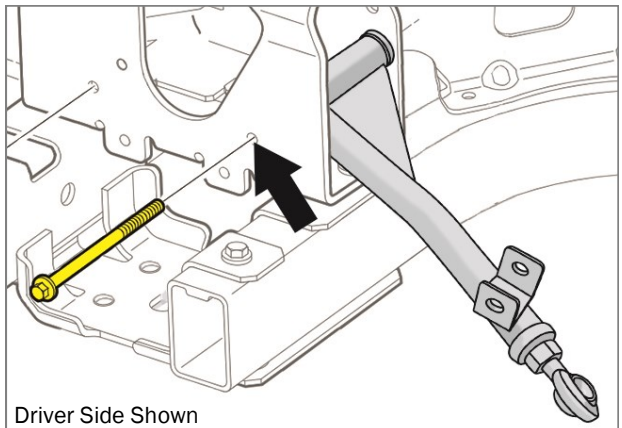

- Attach the shocks to the new A-arms using (2) 8mm x 50 Hex Head Bolts, (4) 8mm Flat Washers and (2) 8mm Nylock Nuts.
- Reinstall the steering rack using the Original Hardware.
- Position the new front suspension in front of the cart with the RHOX plate facing forward. Put a drop of Thread Locking Compound on the threads of the (4) 10mm x 45 Hex Head Bolts.

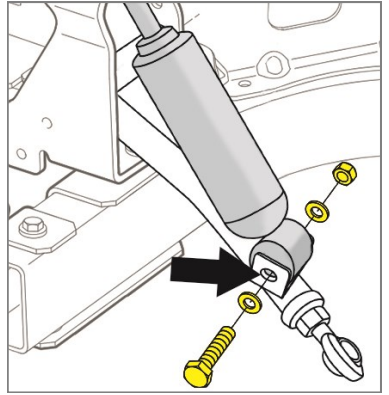

- Fasten the new front suspension to the chassis where the original suspension was removed using the original leaf spring clamp, (4) 10mm x 45 Hex Head Bolts with Thread Locking Compound and (4) 10mm Flat Washers.

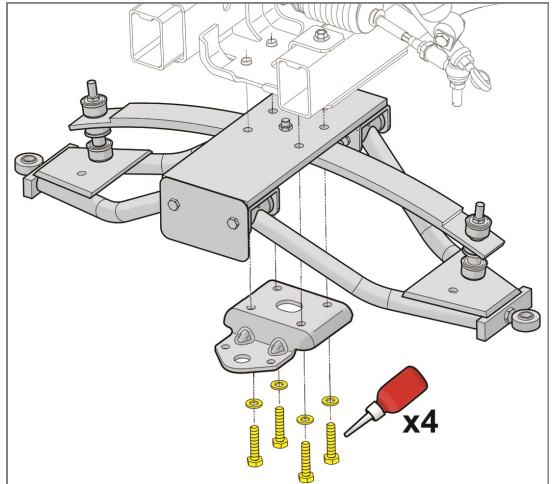

NOTE: Additional help is recommended on this step to support the suspension.

- Grease the fittings on the lower A-arms using a general purpose automotive grease.
- Remove the (4) Socket Cap Screws from the new spindles. Place a drop of Thread Locking Compound on the bottom (2) Socket Cap Screws. Fasten the spindles to the upper and lower A-arms using the (4) Socket Cap Screws (black arrows).

NOTE: The driver and passenger side A-arms are different. The driver side spindle is shown to the right.

If needed, use a jack to raise the lower A-arm and relieve the spring tension.

Adjustments for camber will be made to the spindles at the end of the installation.

- Fasten the tie rod ends onto the spindles using the Original Hardware and Safety Pins (red arrow).

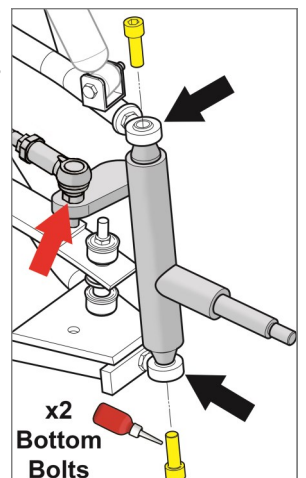

10. Tighten any hardware left loose in this section.
11. Reinstall the hubs and dust caps that were removed on page 3 using the Original Hardware. Hand tighten.
12. Install the (2) front tires and wheels. The stock tires and wheels will not work on the newly lifted cart. Fully tighten the lug nuts on both wheels.

NOTE: It is recommended to use a wheel with at least a 1" offset.

13. Once the tires and wheels are fully secure, place the jack under the cart. Remove the jack stands and lower the cart. Remove the chocks behind the rear wheels.

NOTE: The front bumper will remain off until the camber and toe adjustments are made at the end of the installation.

Installation Preparation (Rear of the Cart)

Safety Note: Proper eye and mouth protection should be worn during this section to protect the installer from falling debris when working under the cart.

The rear axle is only held up by the (2) leaf springs and the jack. For safety reasons, complete one side of the suspension at a time.

1. Engage parking brake.
2. Turn key OFF.
3. Electric Carts Only: Place Tow/Run Switch in TOW.
4. Chock the front of the front wheels.
5. Remove the hub caps (if any). Loosen the lug nuts on both rear wheels but do not remove them.
6. Place a jack securely under the rear axle. Safely lift the rear end of the cart enough to accommodate the additional height of the larger tires and wheels.
7. Place jack stands under the chassis on both sides of the cart to stabilize it. DO NOT remove the jack.
8. Fully remove the (8) rear lug nuts, tires and wheels. Discard.

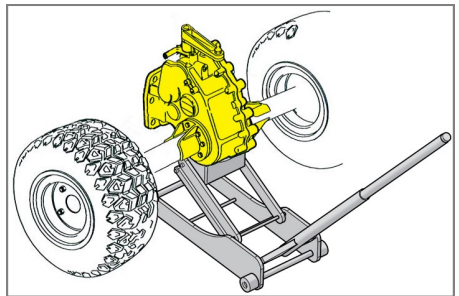

9. Disconnect the bottom portion of the driver side shock from the shock mounting plate (black arrow). Push the shock upward and out of the way. Retain hardware.
10. With the axle supported by the jack, remove the (2) nuts holding the driver side U-bolt around the rear axle, leaf spring and shock mounting plate (red arrows). Remove and discard the U-bolts. Retain shock mounting plate.

CAUTION: Complete one side at a time.

11. Remove the driver's side leaf spring from the rear shackle by removing the shackle bolt on the rear portion of the leaf spring (green arrow). Retain hardware.
12. Remove the front portion of the leaf spring by removing front pivot bolt (blue arrow). This bolt is also secures the clamp that holds the brake cable (shown in purple). Retain hardware.
13. Remove the leaf spring.
14. Carefully lower the rear axle away from the chassis with the jack. The jack stands will remain in place to support the chassis.

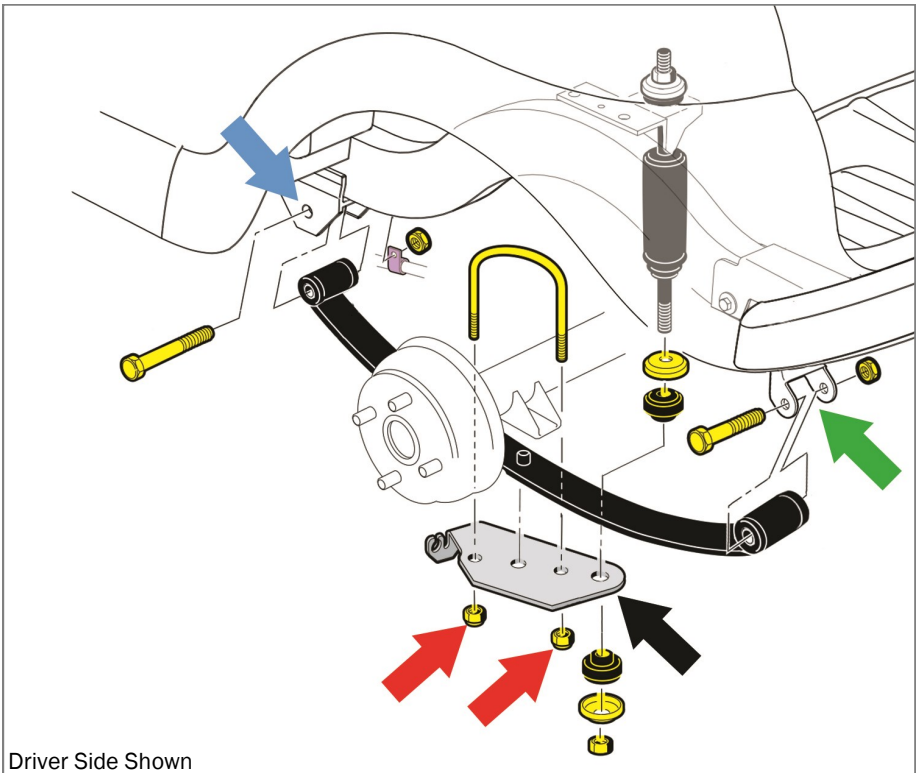

15. Place a lift block on top of the axle, in the perch.
16. Place the leaf spring on top of the lift block. The alignment pin on the spring should seat in the hole on the lift block.
17. Reattach the front portion of the leaf spring and the brake cable clamp removed in step 12 using the original pivot bolt (blue arrow). If the brake cable is too short, leave the brake cable loose and support it with a heavy duty wire tie versus the factory brake cable clamp.
18. Once the spring is seated, place the new shock mounting plate on top of the leaf spring as shown. The alignment pin on the leaf spring will seat in the small hole in the shock mounting plate.

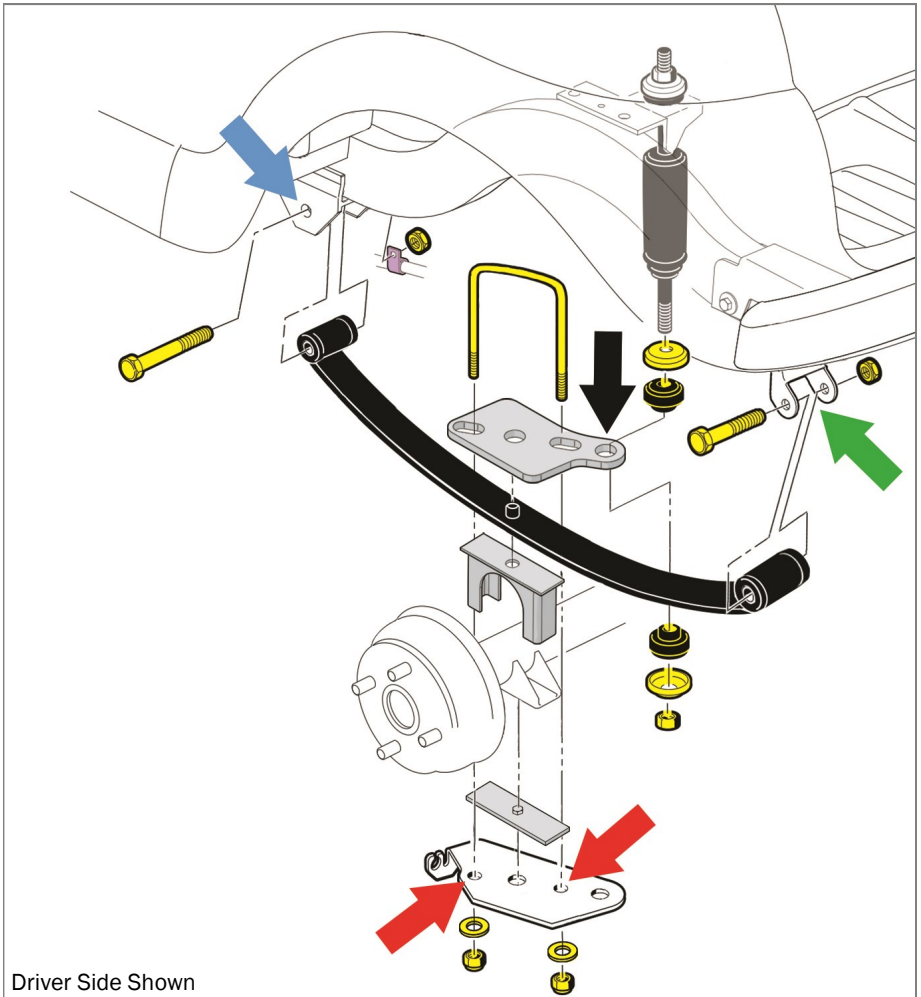

Driver Side Shown

19. Fasten (1) 6mm x 10 Hex Head Bolt and (1) 6mm Nylock Nut to the hole in the centering plate. This will be used for alignment.

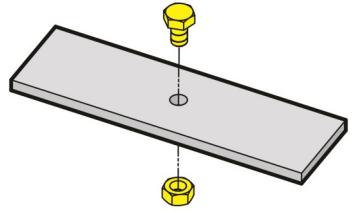

20. Place the centering plate under the lift block perch on the axle as shown on page 8. The 6mm hardware will seat into the alignment hole under the lift perch.
21. Place the original shock mounting plate under the centering plate. The 6mm hardware will seat into the alignment hole.
22. Fasten the new shock plate, leaf spring, lift block, centering plate and old shock mounting plate to the axle with (1) 10mm Square U-Bolt, (2) 10mm Flat Washers and (2) 10mm Nylock Nuts. Hand tighten.

NOTE: Tighten the U-bolt evenly on both sides. Adjustments may be needed to keep all of the parts aligned.

23. Repeat steps 9-22 on the passenger side.
24. Using the jack, safely lift the rear axle and guide the rear portion of the leaf springs to their original positions.
25. Reinstall the rear portion of the leaf springs to the shackles (green arrow, page 8) using the Original Hardware removed in step 11.
26. Pull down the shocks and fasten them onto the new shock mounting plate (black arrow, page 8) using the Original Hardware.
27. If the cart is not high enough to accommodate the larger tires and wheels, raise the cart to the correct height with the jack.
28. Install the (2) new rear tires/wheels on the rear hubs.
29. Remove the jack stands and lower the cart.
30. Remove the jack.

Adjust the Toe and Camber

1. Drive forward and back 20-40 feet to check the toe and camber before making adjustments. Only make adjustments if needed.

NOTE: For stability, an 1/8" toe-in with a positive camber is recommended. This will level out when the cart is loaded.

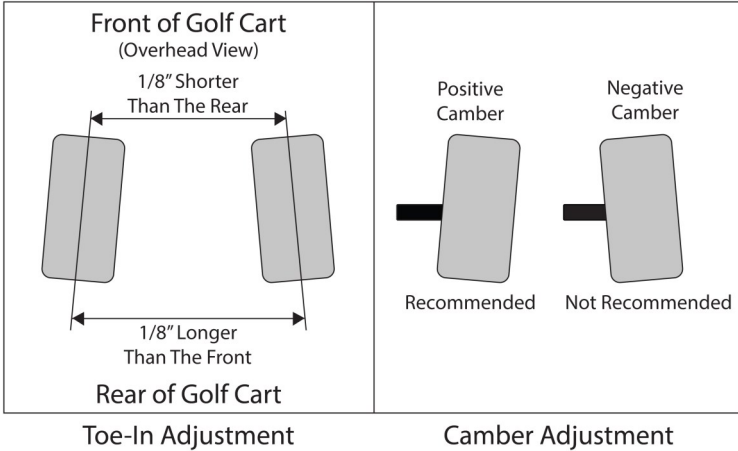

2. Adjust the toe by loosening the jam nut on the tie rod. Lengthen or shorten the tie rod by turning the hex shaped rod adjustment. Adjustments should be made evenly on both sides.

NOTE: Shortening the tie rods increases the toe, lengthening decreases it.

3. Once the desired toe is reached, tighten the jam nuts on the tie rods.

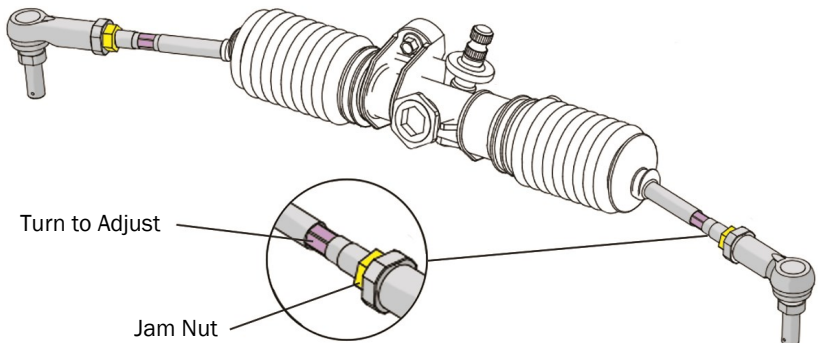

4. To adjust the camber, locate the (2) jam nuts on each of the lower heim joints of the spindles. Turn the nuts to increase or decrease the camber. Adjustments should be made evenly on both sides.

NOTE: If the correct camber cannot be reached by adjusting the lower heim joints, the top heim joints can be adjusted by removing the socket cap screws from the upper portion of the spindles and rotating the heim joints. Adjustments should be made evenly on both sides.

5. Once the desired camber has been reached, tighten the jam nuts on the heim joints.
6. Loosen the top (2) Socket Cap Screws on the spindles. Apply a drop of Thread Locking Compound to each of the Socket Cap Screws and fully tighten.
7. Reinstall the front bumper with the original hardware.

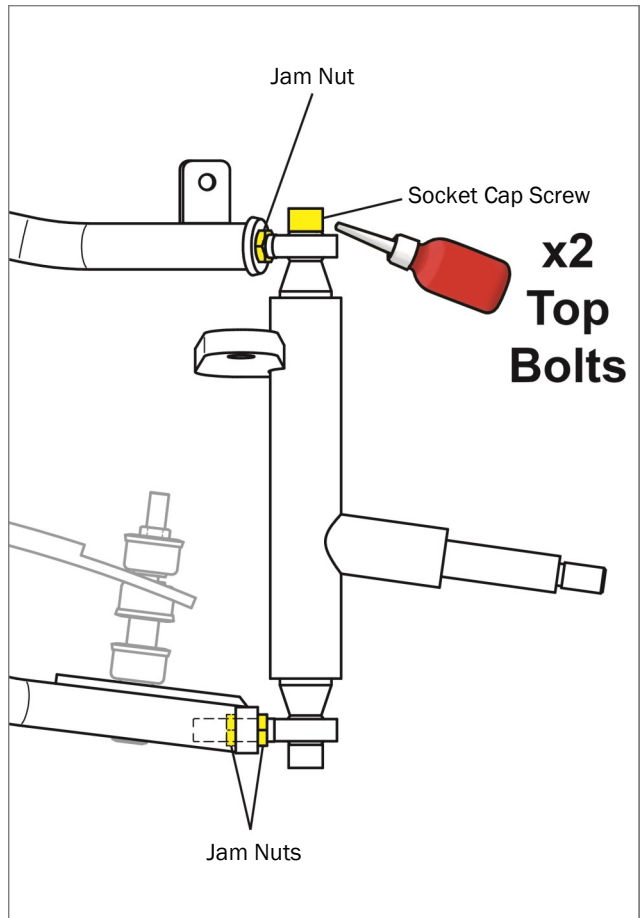

This completes the installation of your
RHOX Standard A-Arm Lift Kit. Please enjoy safely!

Scan QR code or use the link below to
view the installation video.

<https://vimeo.com/user39935056>



**RUGGED
STARTS
HERE**